

**MODELS FOR THE STUDY OF MECHANICAL
RESPONSE OF THE SOLIDS AND SYSTEMS OF
SOLIDS**

HABILITATION THESIS

Domain: MECHANICAL ENGINEERING

Author: Dr.Eng. SCUTARU Maria Luminita

BRASOV 2015



EVOLUTION OF PROFESSIONAL AND ACADEMIC CAREER

Teaching activity

1998-2000 – *junior assistant* – Transilvania University of Brasov, Faculty of Mechanical Engineering, Department of Mechanical Engineering

2000-2005 – *assistant professor* - Transilvania University of Brasov, Faculty of Mechanical Engineering, Department of Mechanical Engineering

2005-2014 –*lecture*- Transilvania University of Brasov, Faculty of Mechanical Engineering, Department of Mechanical Engineering

2014 – present - *associate professor* - Transilvania University of Brasov, Faculty of Mechanical Engineering, Department of Mechanical Engineering

Education and training:

1992-1997- Licence in Industrial Engineering, Transilvania University of Brasov , Faculty of Wood Industry

- **1999 - 2006** - Transilvania University of Brasov - Ph.D. degree in Industrial Engineering, with "Wood and wooden materials thermo insulation panels used in building construction", Doctor father – Prof.Ph.D. Eng. Ivan Cismaru
- **2006-2008** - Transilvania University of Brasov, Faculty of Mechanical Engineering - Masters degree in Computational Mechanics

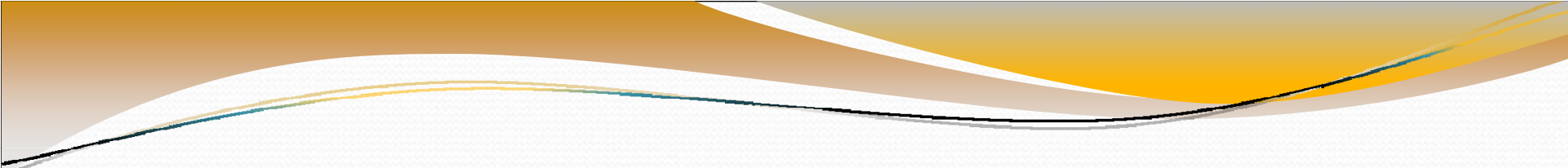
- 
- **2010-2013-** Postdoc studies in the field of innovative products and processes, research on the topic *Determination of non-stationary dynamic response of structures of polymeric composite materials with application in the automotive and engineering – DINACOM*, Transilvania University of Brasov, Faculty of Mechanical Engineering,



Other responsibilities related to the scientific activity include:

Post-graduate courses:

23 -27 oct. 2006 - *Dynamical Analysis of Vehicle System- Theoretical Foundations and Advanced Applications* , Udine, Italia

9-12. dec. 2006 - *Strain Gage Installation Workshop* , Darmstadt, Germania

19-23 nov. 2007 - *Optical Measuring Techniques GOM* , Braunschweig, Germania

8-12 sept. 2008 - *Computational and Experimental Mechanics of Advanced Materials*, Udine



Member of Organizing Committees of

- COMEC 2005, 2007, 2011, 2013, 2015 – *International Conference on Computational Mechanics and Virtual Engineering*, Brasov;
- COMAT 2006, 2008, 2010, 2012, 2014 - *International Conference and Advanced Composite Materials Engineering*, Brasov;
- since 2013 – IM-IFR program coordinator, Department of Mechanical Engineering, Faculty of Mechanical Engineering.

Concerning the publishing activity:

- 23 papers published in ISI Proceedings volumes;
- **16 papers published in ISI journals;**
- **15 papers cited in ISI journals;**
- 98 papers published in Conference Proceedings;
- 3 specialized monographs;
- 12 national publishing books (4-unique author, 4- first author)
- 1 published chapter in international books;
- 3 patent proporsal
- experience as manager or member of 12 research projects (manager – 1 project research; member – 11 research grants)

Journals where are published my papers
ISI indexed journals



Journal of Optoelectronic and Advanced Materials

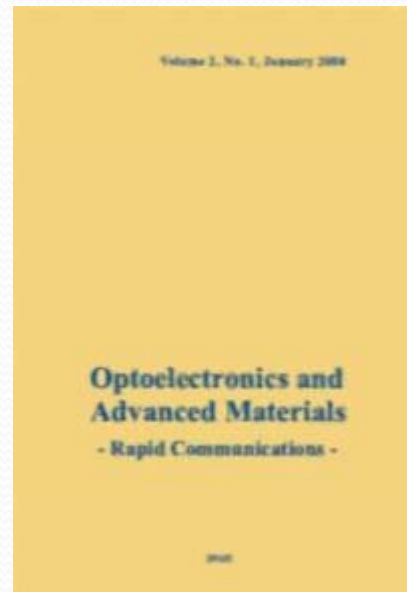

Optoelectronic and Advanced Materials

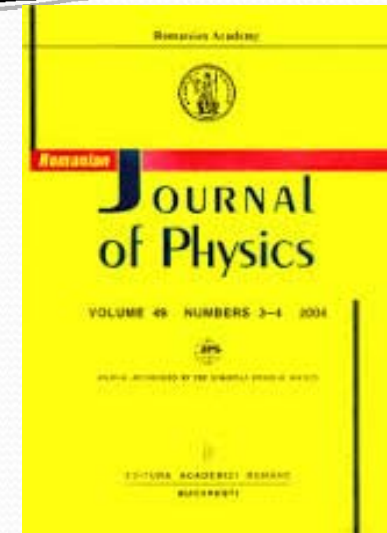

Romanian Journal of Physics

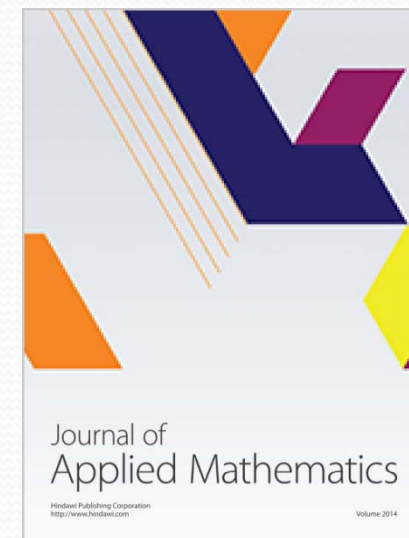

Journal of Applied Mathematics

Habilitation preliminary conditions

1. Scientific research activity, recognition and visibility -
(min. 10 points including 6 points from CDI-ART)

- realized 43,162 points including 28,642 from CDI-ART

2. Teaching activity - *(min. 10 points including 6 points from DID-MSD)*

- realized 22,92 points from DID-MSD

3. Research grants and contracts –*(min. 10 points including 6 points as grant/project Manager)*

- realized 32,105 points including 8,913 points as project Manager

TOTAL 101,187 points

3,27 x minimum necessary points

CONTENTS

Part I

1. Dynamical Analysis of the Mechanical System with Two Degree of Freedom Applied to the Transmission of the Wind Turbine

2. Analysis of the Motion Equations and Dynamic Response of a Multibody System with Elastic Element

Part II

3. Mechanical Properties Identification and Tests on Advanced Composite Materials

4. Toward the use of irradiation for the composite materials properties Improvement

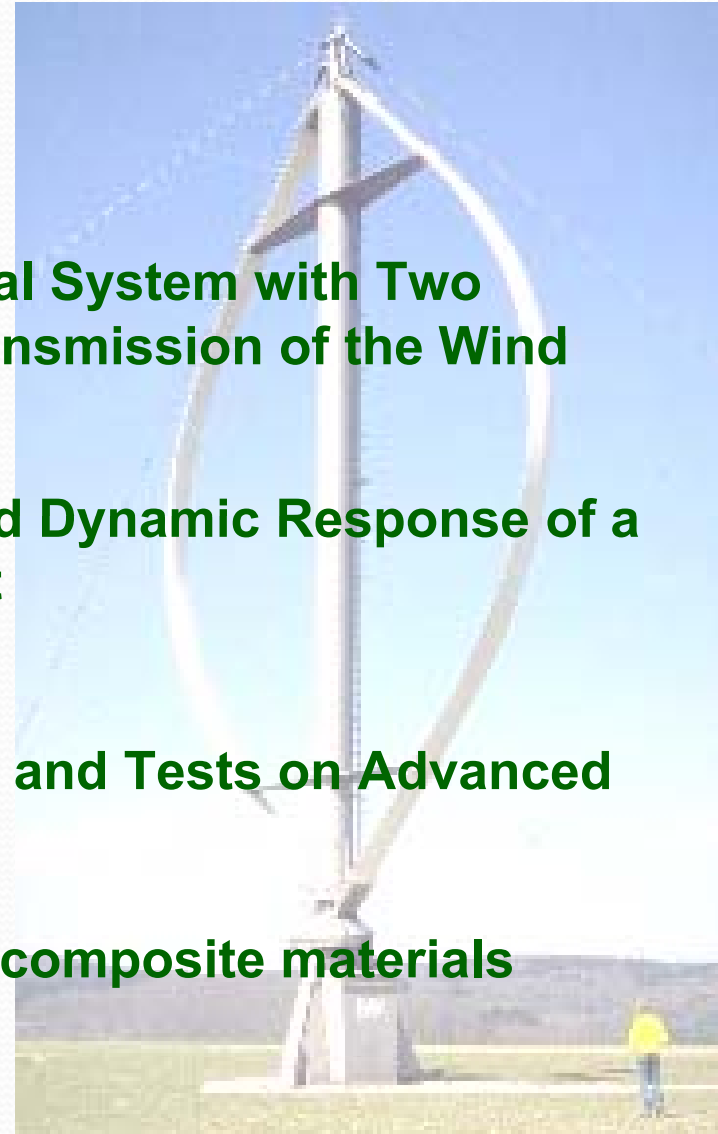

Chapter 1

DYNAMICAL ANALYSIS OF THE MECHANICAL SYSTEM WITH TWO DEGREE OF FREEDOM APPLIED TO THE TRANSMISSION OF THE WIND TURBINE

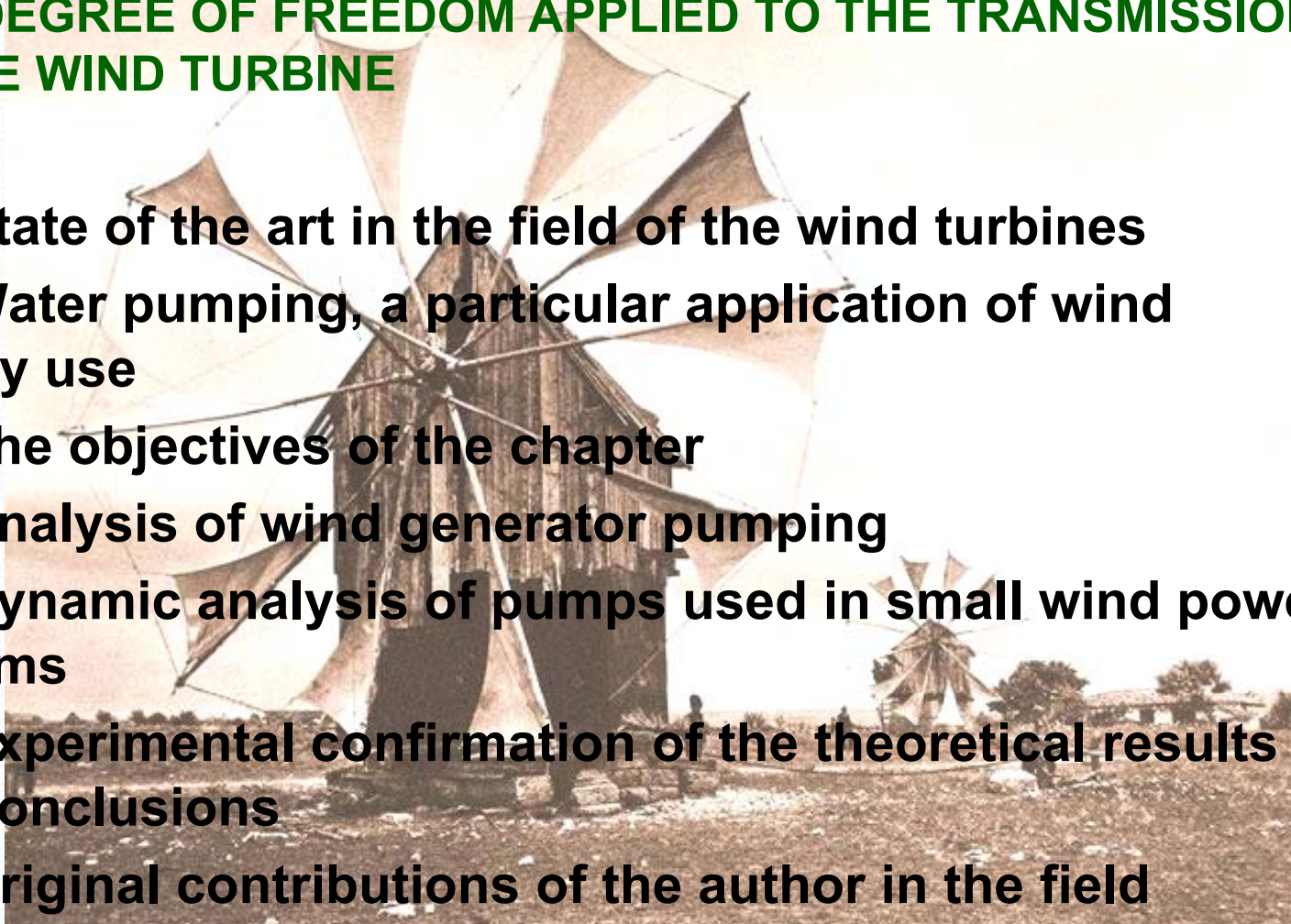
- 1.1. State of the art in the field of the wind turbines
 - 1.2. Water pumping, a particular application of wind energy use
 - 1.3. The objectives of the chapter
 - 1.4. Analysis of wind generator pumping
 - 1.5. Dynamic analysis of pumps used in small wind power systems
 - 1.6. Experimental confirmation of the theoretical results
 - 1.7. Conclusions
 - 1.8. Original contributions of the author in the field
- 

Classical solution

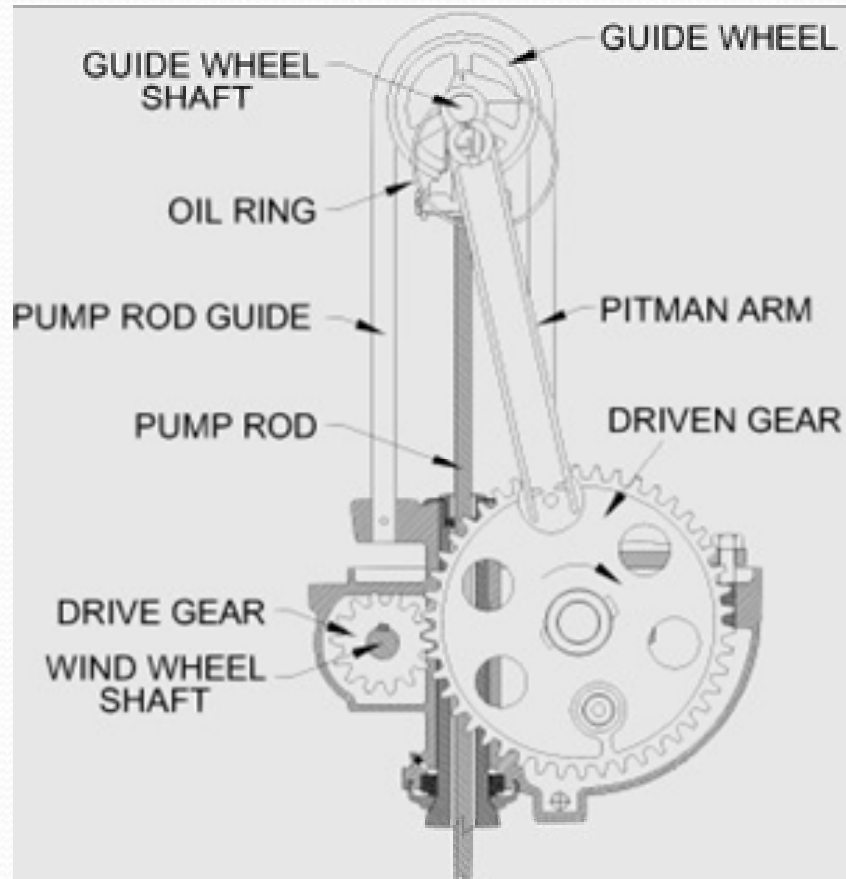

Front view

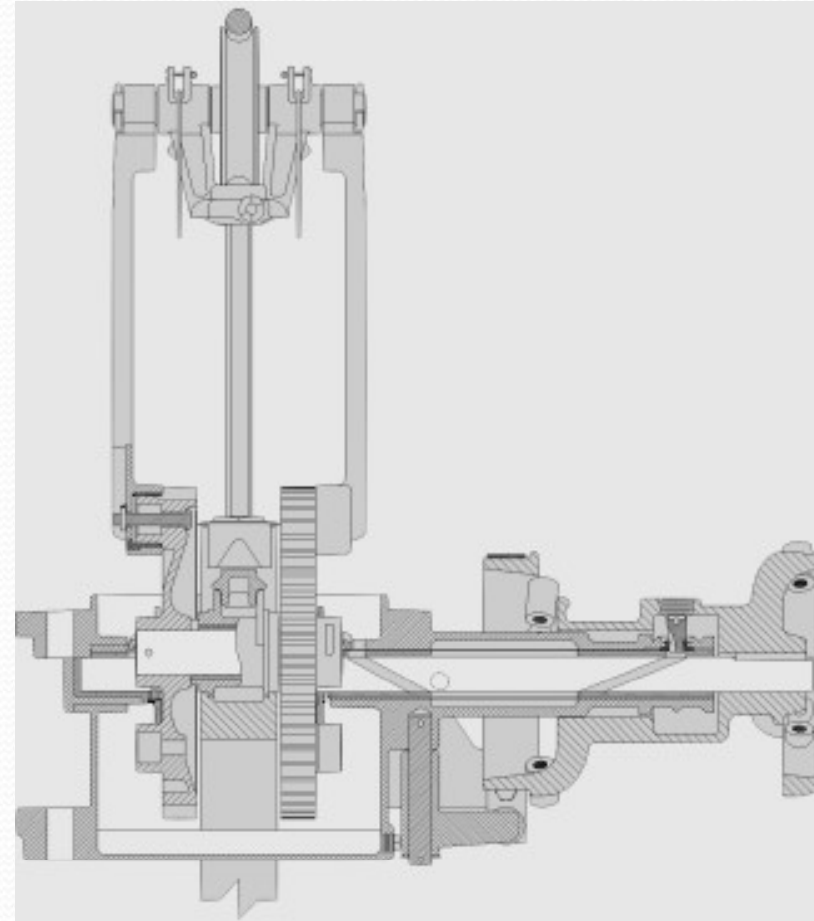

Side view

Sketch of mechanism that transform the blade rotation in translation

Classical solution - Samples



Sketch of an eolian waterpump used in a farm

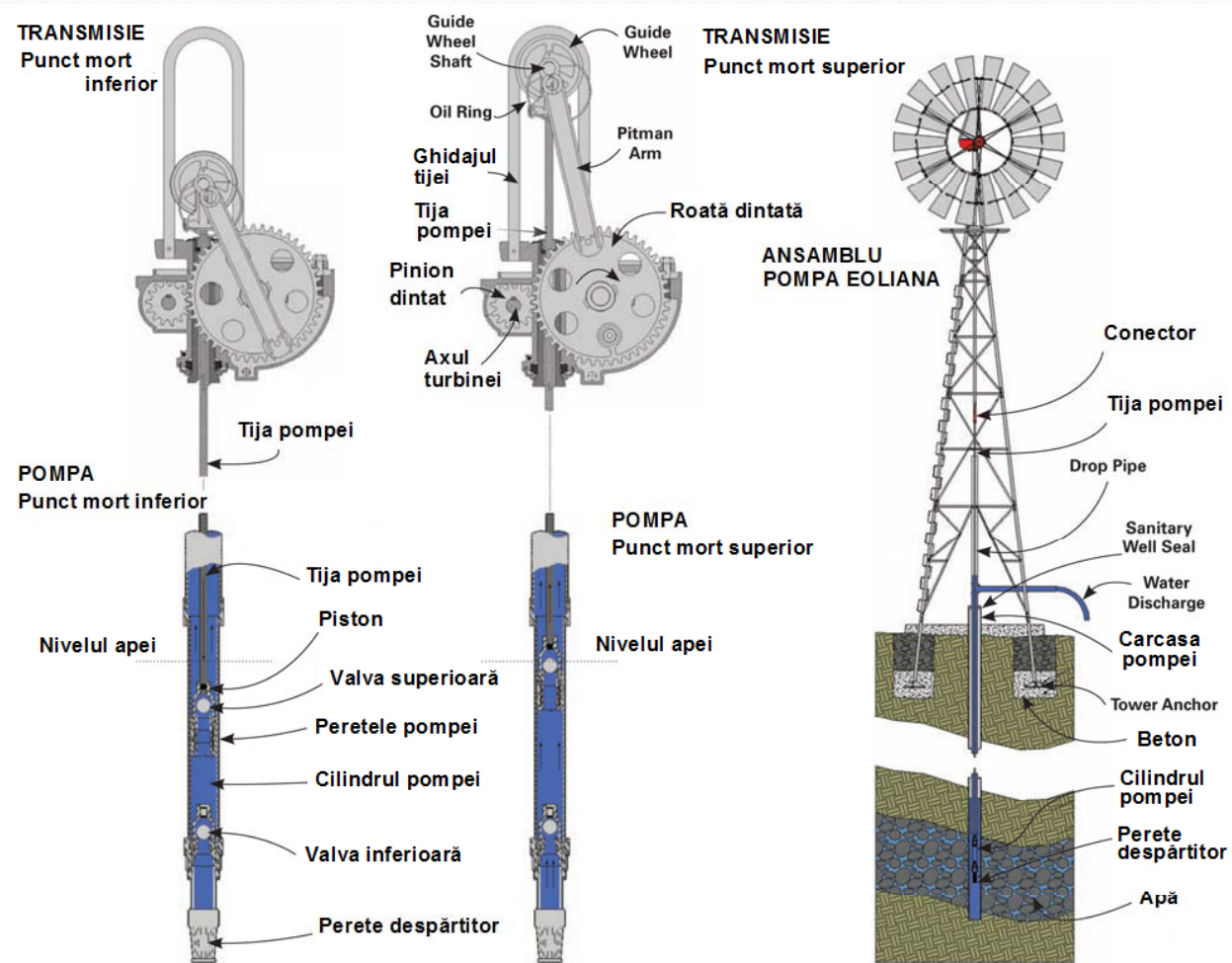

Writing equations of motion for a classic pump with single or double effect for a basic mechanical transmission

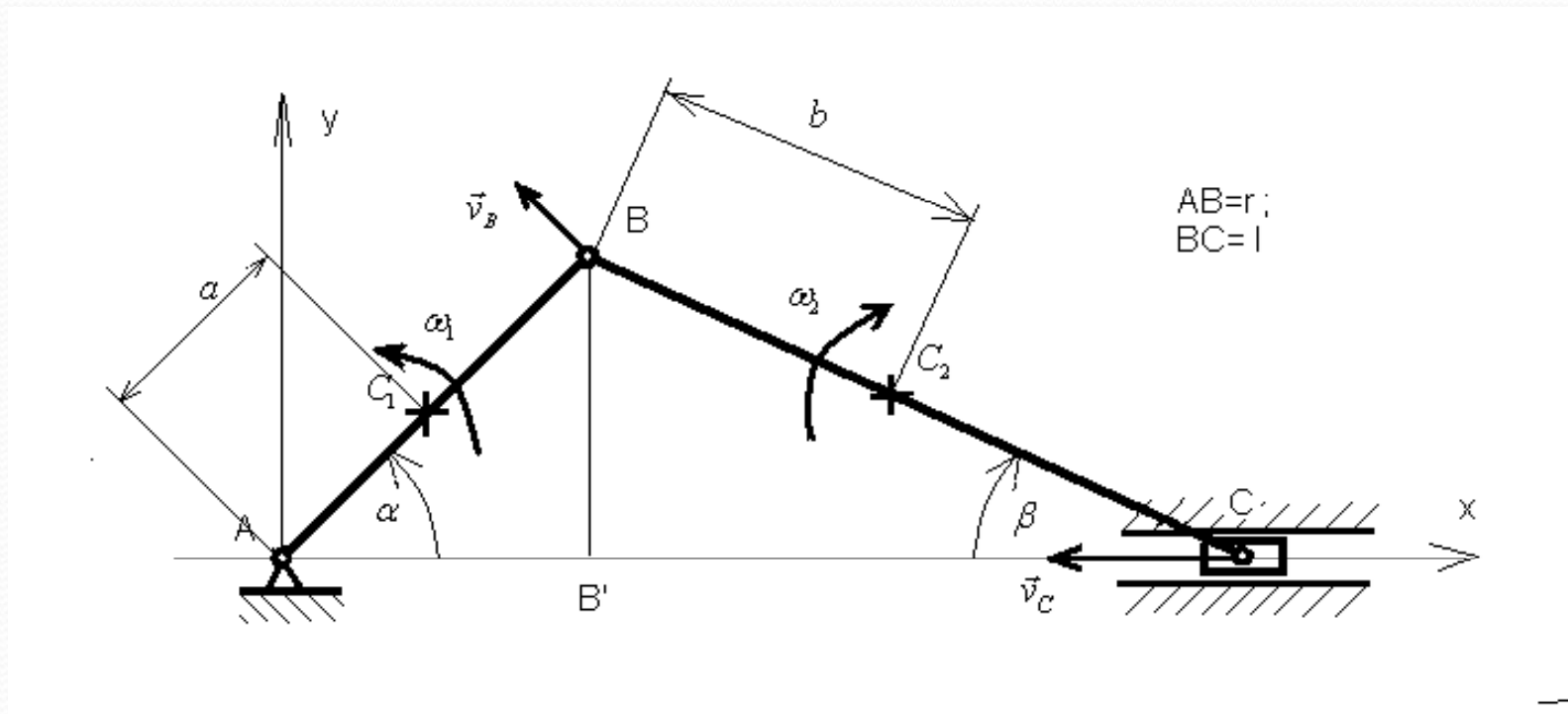

KINEMATICS AND DYNAMICS

Accelerations:

$$\begin{Bmatrix} \ddot{x}_{C1} \\ \ddot{y}_{C1} \\ \varepsilon_1 \\ \ddot{x}_{C2} \\ \ddot{y}_{C2} \\ \varepsilon_2 \\ \ddot{x}_C \end{Bmatrix} = \begin{Bmatrix} -a \sin \alpha \\ a \cos \alpha \\ 1 \\ -r \sin \alpha + bt \sin \beta \\ r \cos \alpha + bt \cos \beta \\ t \\ -r \sin \alpha + lt \sin \beta \end{Bmatrix} \varepsilon_1 + \begin{Bmatrix} -a \cos \alpha \\ -a \sin \alpha \\ 0 \\ -r \cos \alpha - bt^2 \sin \beta + bu \sin \beta \\ -r \sin \alpha + bt^2 \sin \beta + bu \cos \beta \\ u \\ -r \sin \alpha + lt^2 \sin \beta + lu \cos \beta \end{Bmatrix} \omega_1^2$$

Motion equations:

$$\begin{bmatrix} m_1 & 0 & 0 & 0 & 0 & 0 & 0 \\ 0 & m_1 & 0 & 0 & 0 & 0 & 0 \\ 0 & 0 & J_{C1} & 0 & 0 & 0 & 0 \\ 0 & 0 & 0 & m_2 & 0 & 0 & 0 \\ 0 & 0 & 0 & 0 & m_2 & 0 & 0 \\ 0 & 0 & 0 & 0 & 0 & J_{C2} & 0 \\ 0 & 0 & 0 & 0 & 0 & 0 & m_3 \end{bmatrix} \begin{Bmatrix} \ddot{x}_{C1} \\ \ddot{y}_{C1} \\ \varepsilon_1 \\ \ddot{x}_{C2} \\ \ddot{y}_{C2} \\ \varepsilon_2 \\ \ddot{x}_C \end{Bmatrix} = \begin{Bmatrix} X_A + X_B \\ Y_A + Y_B \\ [M_m + X_A a \sin \alpha - Y_A a \cos \alpha - \\ -X_B(r-a) \sin \alpha + Y_B(r-a) \cos \alpha] \\ -X_B + X_C \\ -Y_B + Y_C \\ X_C(l-b) \sin \beta + Y_C(l-b) \cos \beta + X_B b \sin \beta + Y_B b \cos \beta \\ F_r - X_C \end{Bmatrix}$$

Final form of motion equations:

$$\begin{aligned} & [m_1 a^2 + J_{C1} + m_2 r^2 + m_2 b^2 t^2 + 2m_2 rbt \cos(\alpha + \beta) + J_{C2} t^2 + \\ & + m_3 (-r \sin \alpha + lt \sin \beta)^2] \varepsilon_1 + [m_2 (rbt^2 \cos(\alpha - \beta) + rbu \cos(\alpha + \beta) - \\ & - rbtsin(\alpha + \beta) - b^2 t^3 \cos 2\beta + b^2 tu) + J_{C2} tu + \\ & + m_3 (-r \sin \alpha + lt \sin \beta)(-r \sin \alpha + lt^2 \sin \beta + lu \cos \beta)] \omega_1^2 = \\ & = M_m + F_r (-r \sin \alpha + lt \sin \beta) \\ & J(\alpha) \ddot{\alpha} + J'(\alpha) \dot{\alpha}^2 = M(\alpha) \end{aligned}$$

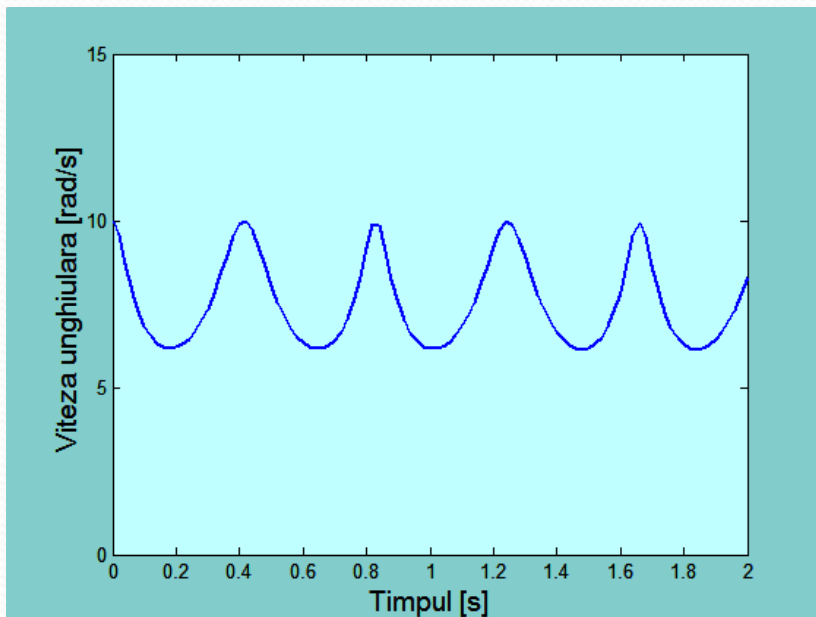
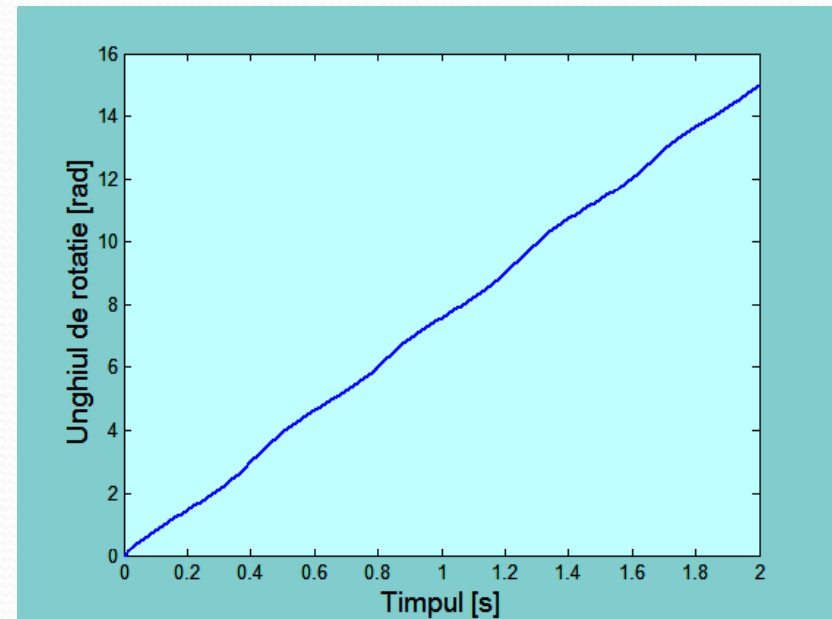
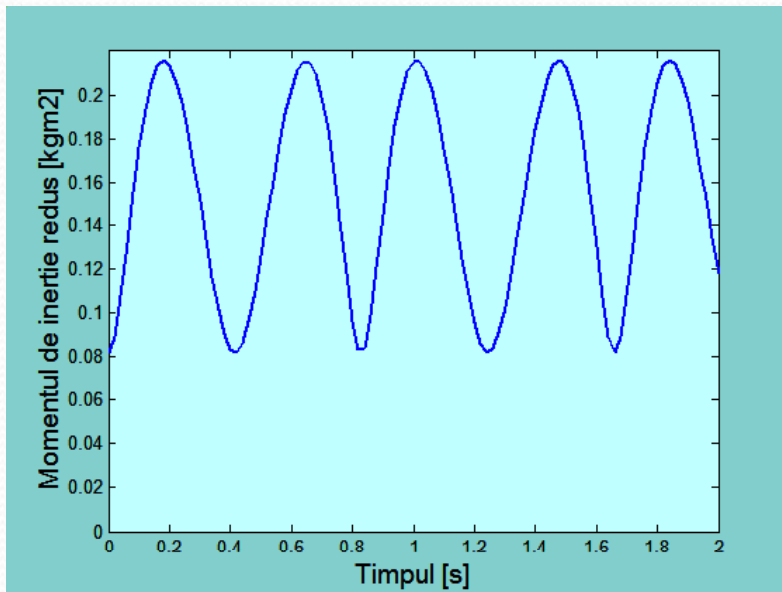

Angle of rotation and
angular speed obtained
after numerical integration

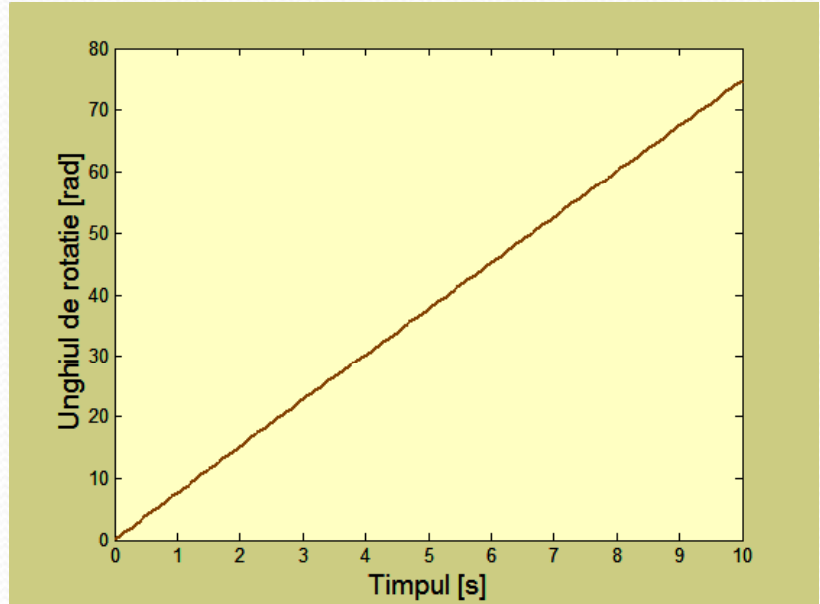
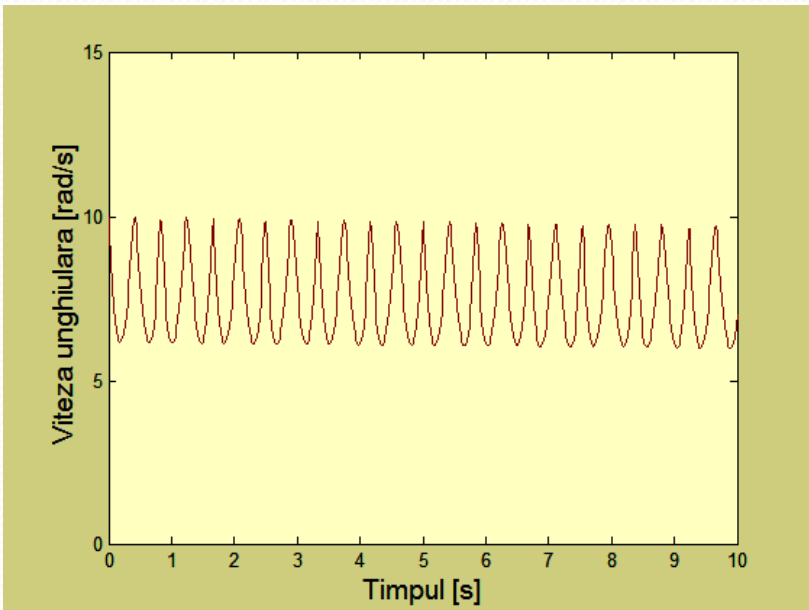
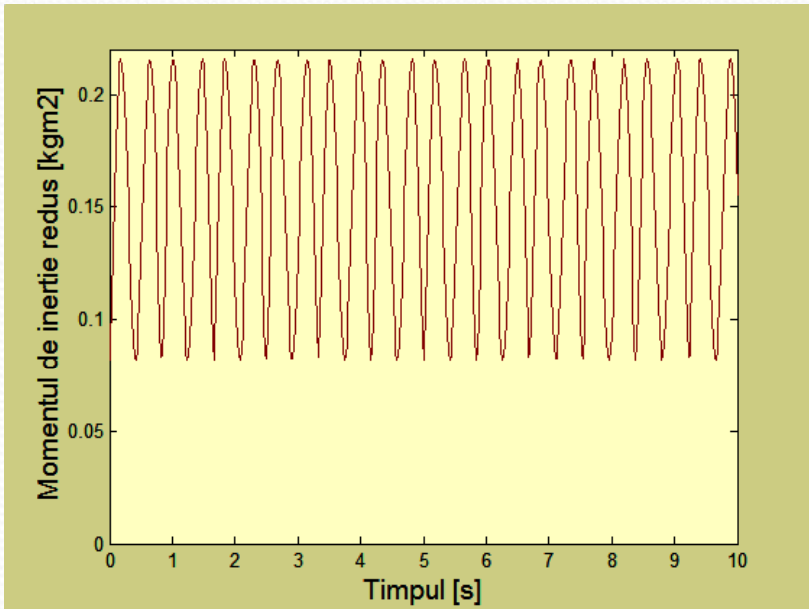

Angle of rotation and angular speed obtained after numerical integration

PROPOSED MECHANISM WITH TWO DEGREE OF FREEDOM – “MECHANISM CLOSED BY INERTIA”

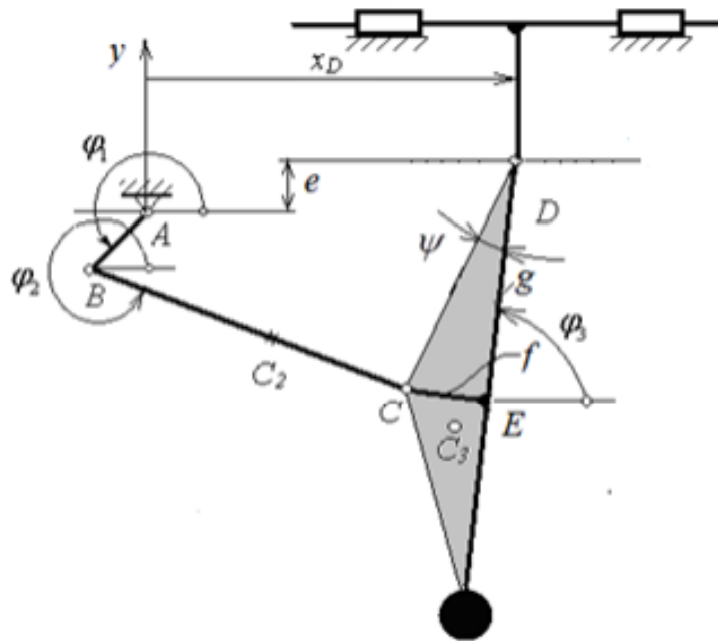

Mechanism with two
degree of freedom

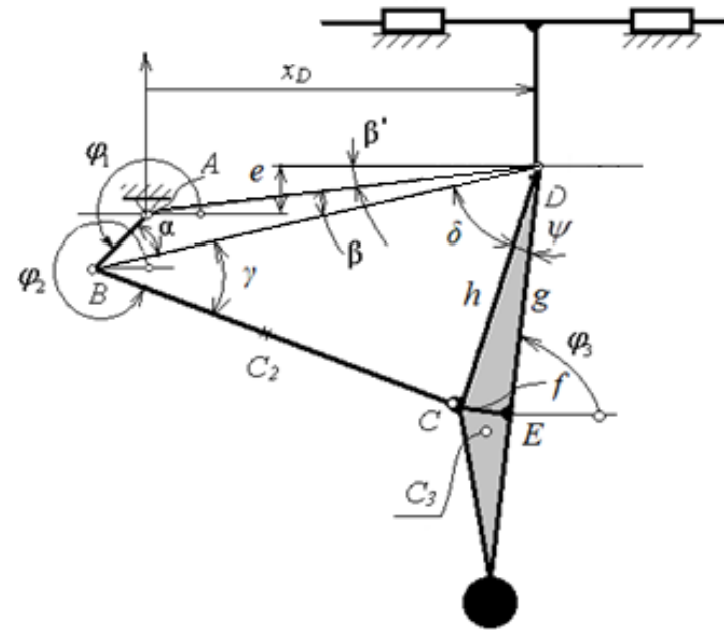

Geometry of the
mechanism

Free body diagrams

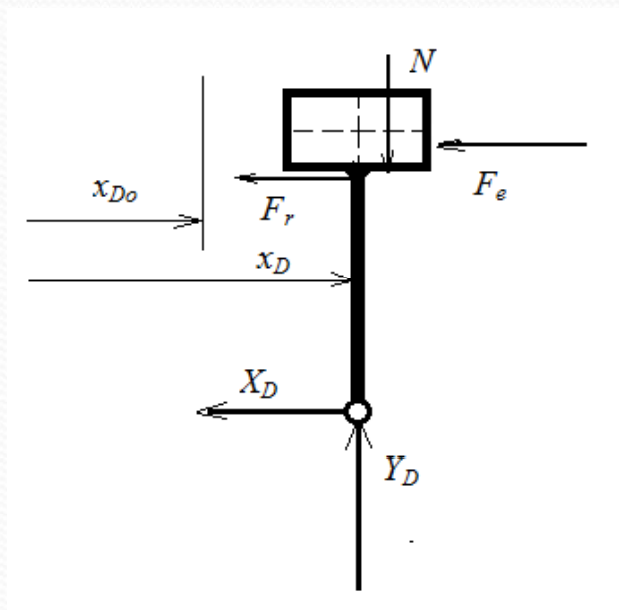
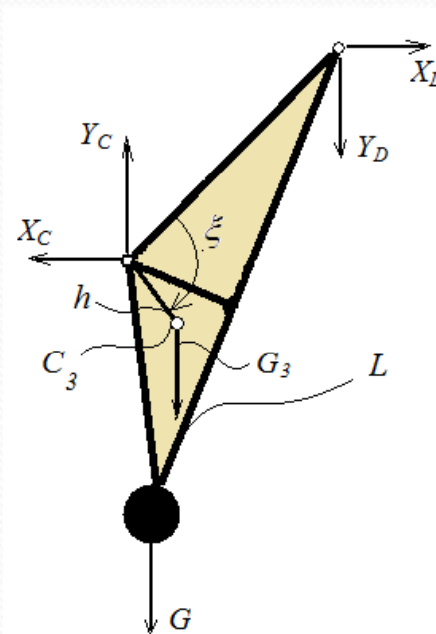
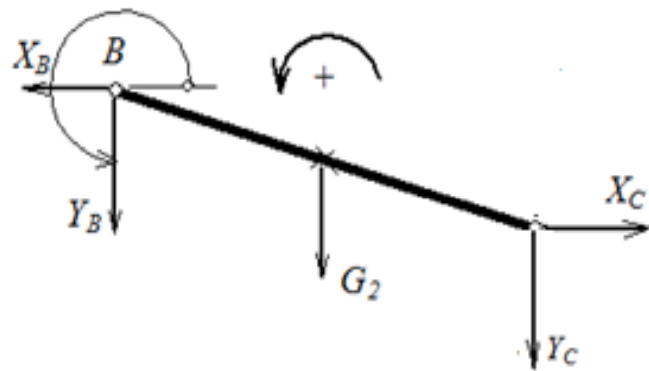
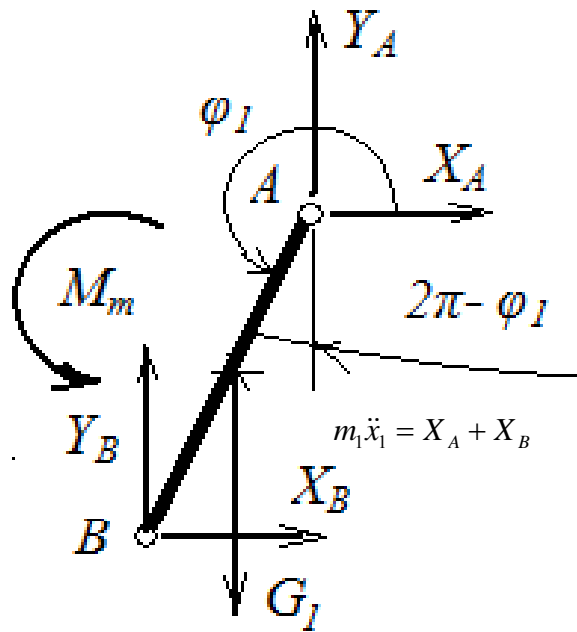

Equation of motions

$$\begin{bmatrix} \{A_1\}^T [m] \{A_1\} & \{A_1\}^T [m] \{A_2\} \\ \{A_2\}^T [m] \{A_1\} & \{A_2\}^T [m] \{A_2\} \end{bmatrix} \begin{Bmatrix} l_1 \varepsilon_1 \\ \ddot{x}_D \end{Bmatrix} +$$

$$+ \begin{bmatrix} \{A_1\}^T [m] \{B_1\} & \{A_1\}^T [m] \{B_2\} & \{A_1\}^T [m] \{B_3\} \\ \{A_2\}^T [m] \{B_1\} & \{A_2\}^T [m] \{B_2\} & \{A_2\}^T [m] \{B_3\} \end{bmatrix} \begin{Bmatrix} (l_1 \omega_1)^2 \\ (l_1 \omega_1 \dot{x}_D) \\ (\dot{x}_D)^2 \end{Bmatrix} = \begin{bmatrix} \{A_1\}^T \{Q\} \\ \{A_2\}^T \{Q\} \end{bmatrix}$$

$$X = \begin{Bmatrix} l_1 \varphi_1 \\ x_D \end{Bmatrix} ; \quad \dot{X} = Y \qquad \begin{Bmatrix} l_1 \varepsilon_1 \\ \ddot{x}_D \end{Bmatrix} = \{\dot{Y}\} =$$

$$= - \begin{bmatrix} \{A_1\}^T [m] \{A_1\} & \{A_1\}^T [m] \{A_2\} \\ \{A_2\}^T [m] \{A_1\} & \{A_2\}^T [m] \{A_2\} \end{bmatrix}^{-1} \begin{bmatrix} \{A_1\}^T [m] \{B_1\} & \{A_1\}^T [m] \{B_2\} & \{A_1\}^T [m] \{B_3\} \\ \{A_2\}^T [m] \{B_1\} & \{A_2\}^T [m] \{B_2\} & \{A_2\}^T [m] \{B_3\} \end{bmatrix} \begin{Bmatrix} (l_1 \omega_1)^2 \\ (l_1 \omega_1 \dot{x}_D) \\ (\dot{x}_D)^2 \end{Bmatrix} +$$

$$+ \begin{bmatrix} \{A_1\}^T [m] \{A_1\} & \{A_1\}^T [m] \{A_2\} \\ \{A_2\}^T [m] \{A_1\} & \{A_2\}^T [m] \{A_2\} \end{bmatrix}^{-1} \begin{bmatrix} \{A_1\}^T \{Q\} \\ \{A_2\}^T \{Q\} \end{bmatrix}$$

Results after integration for t=20 sec

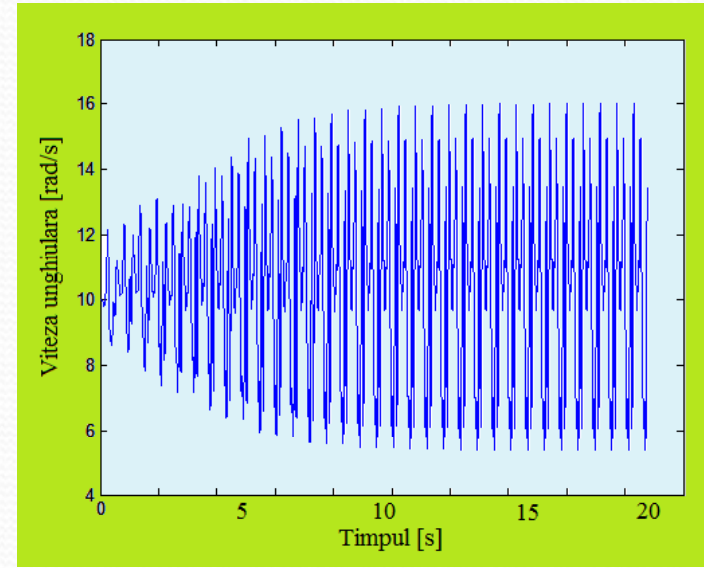
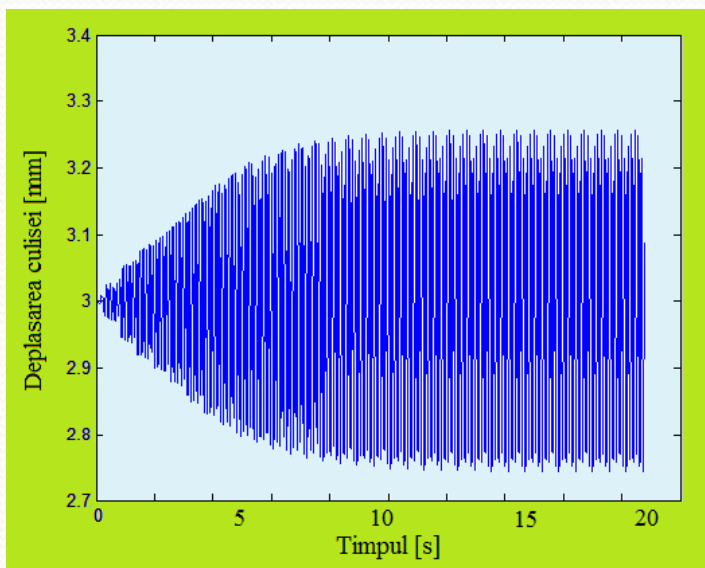
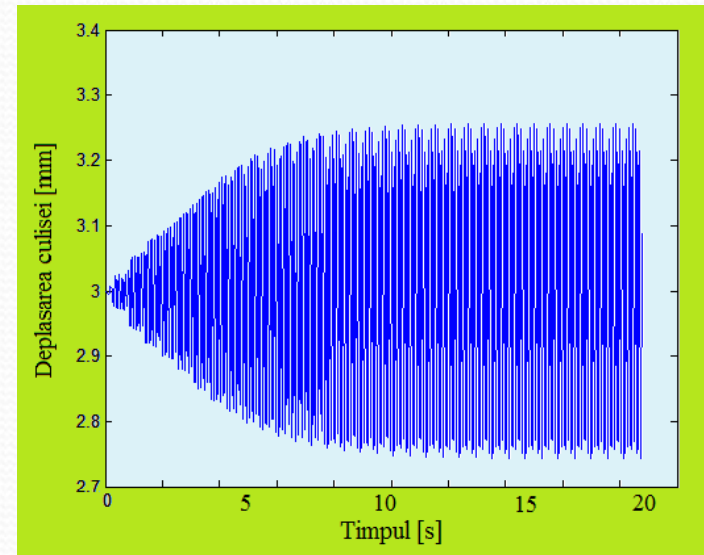
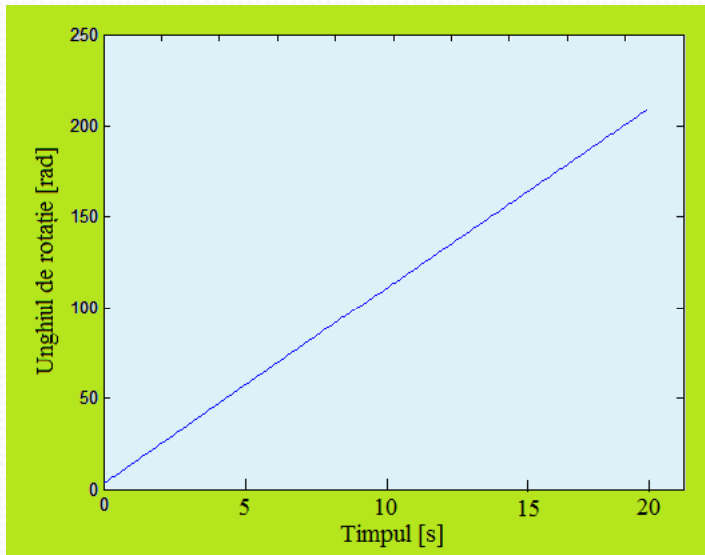

Results after integration for t=30 sec

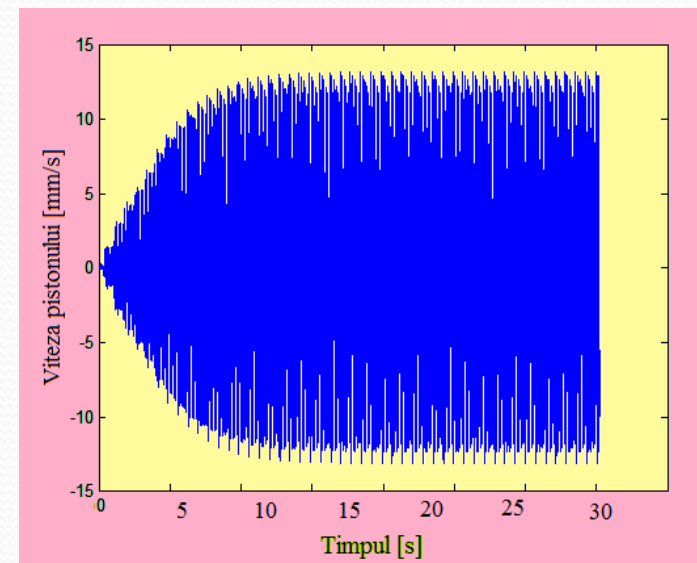
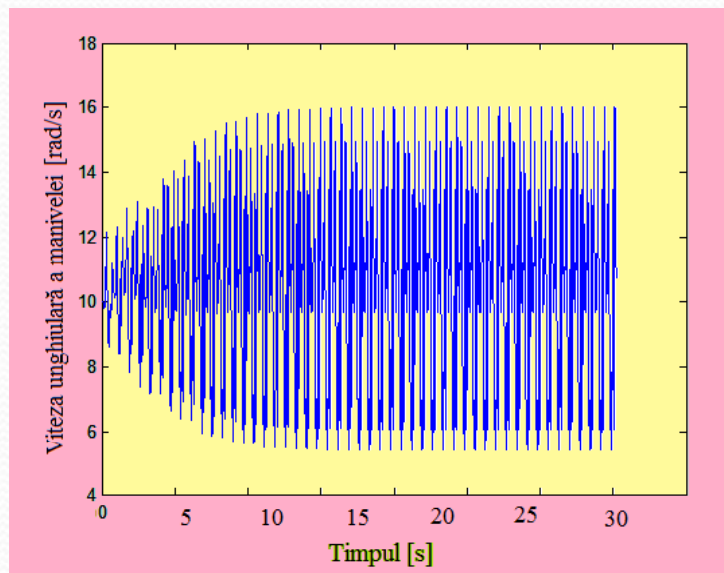
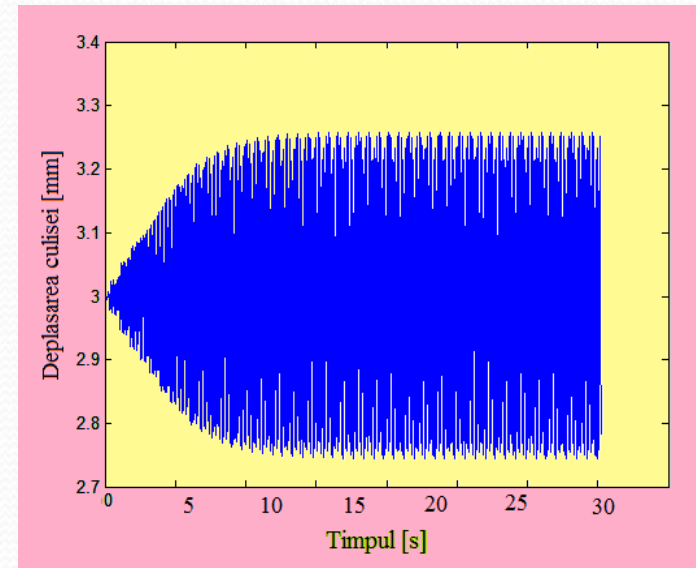
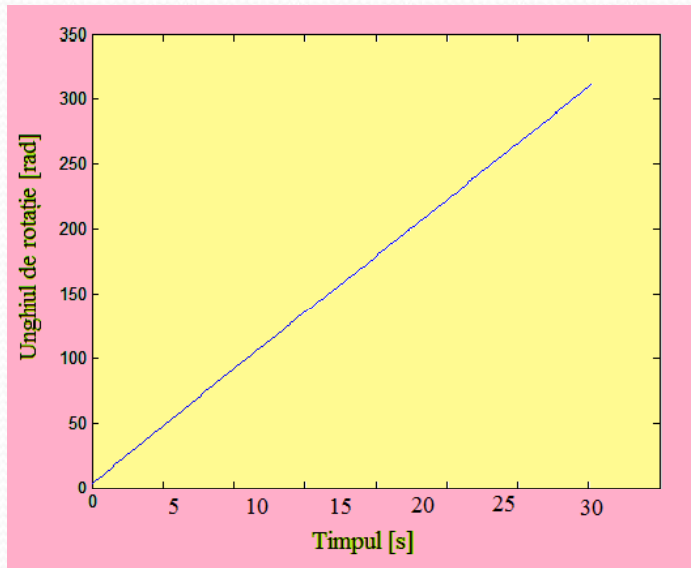

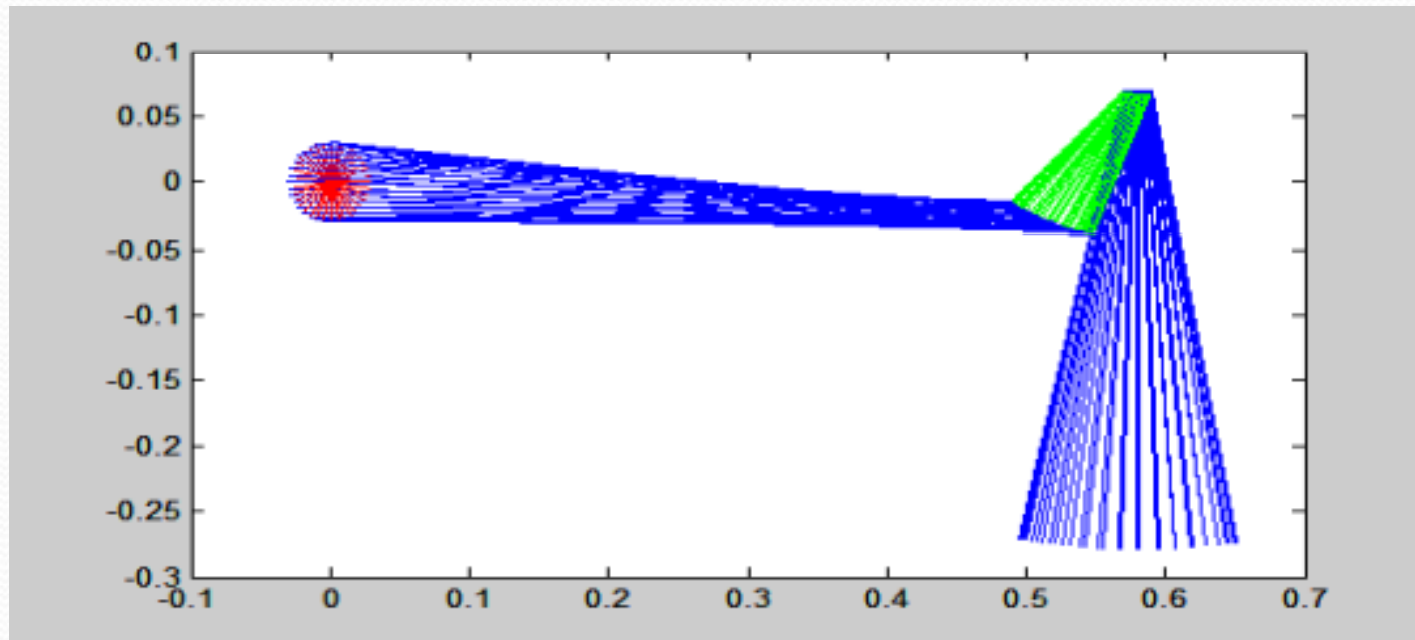

Sketch of the motion of the two degree of freedom system for the angular speed 160 rot./min

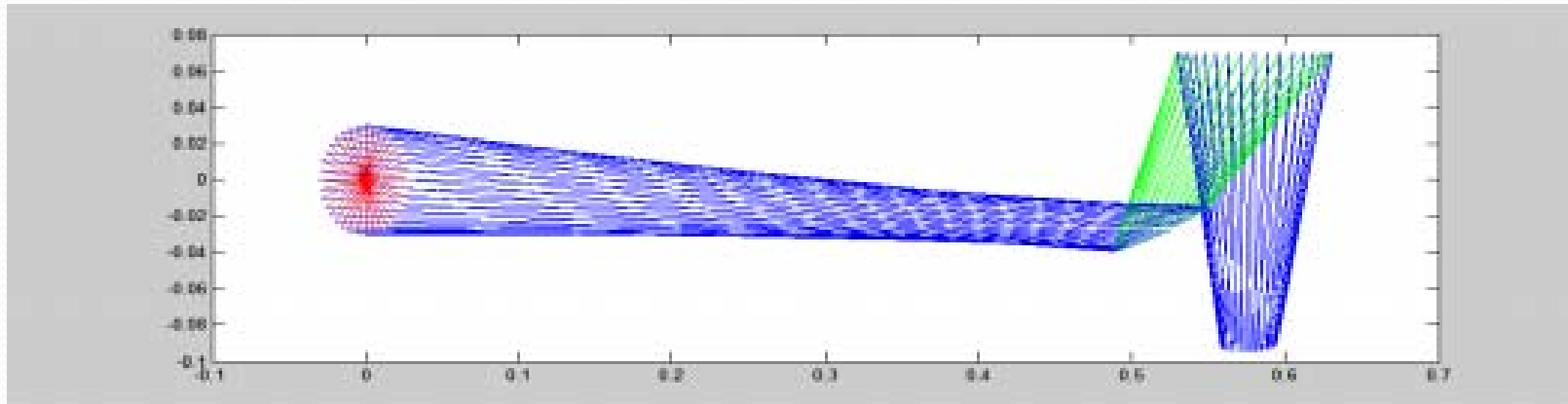

Sketch of the motion of the two degree of freedom system for the angular speed 190 rot./min

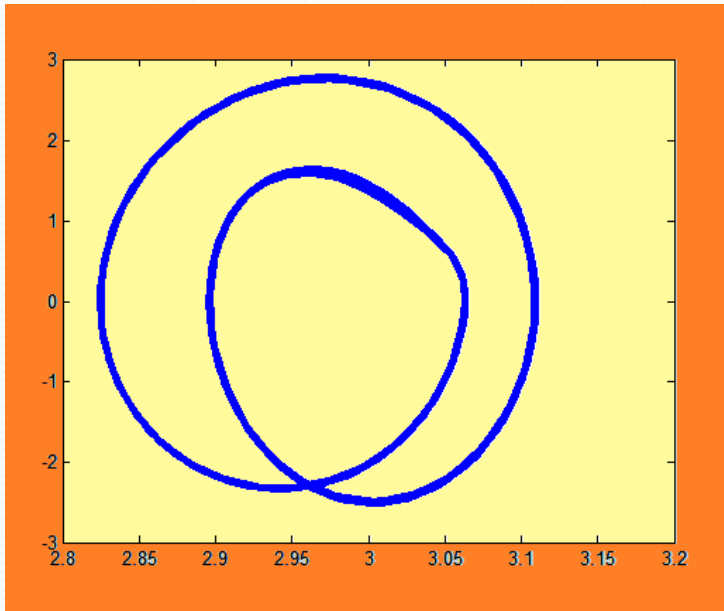

Slider motion representation
in the phase space

Sketch of the mechanism
with markers highlighting

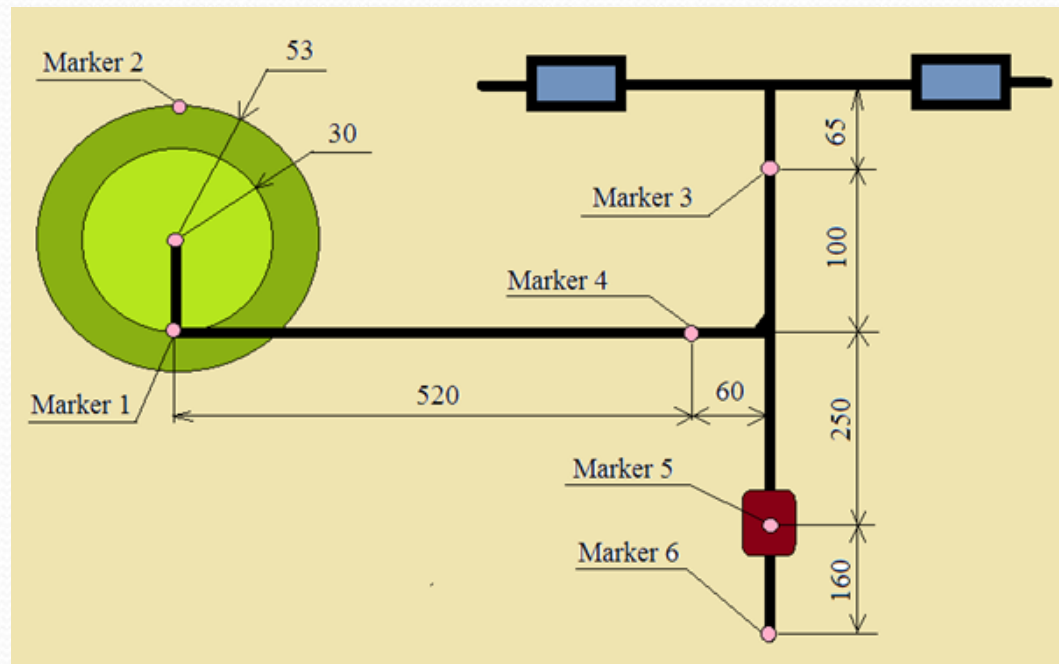

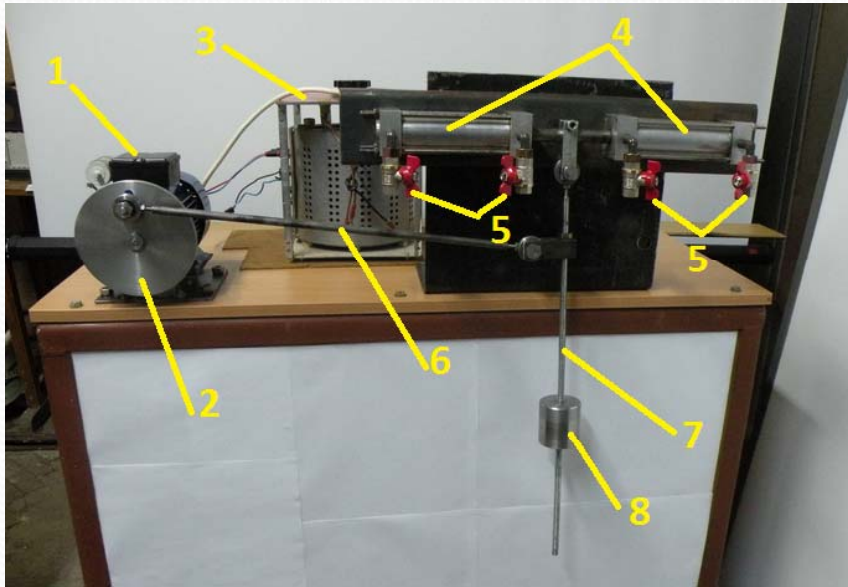

Experimental setup for testing

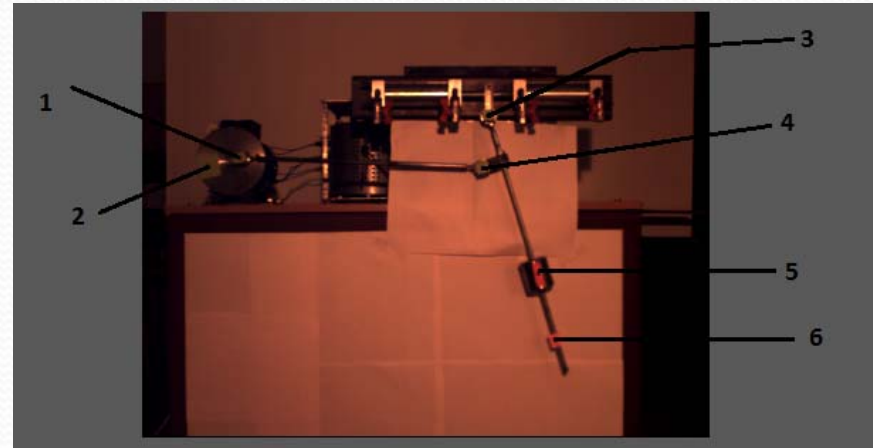

Highlighting the markers

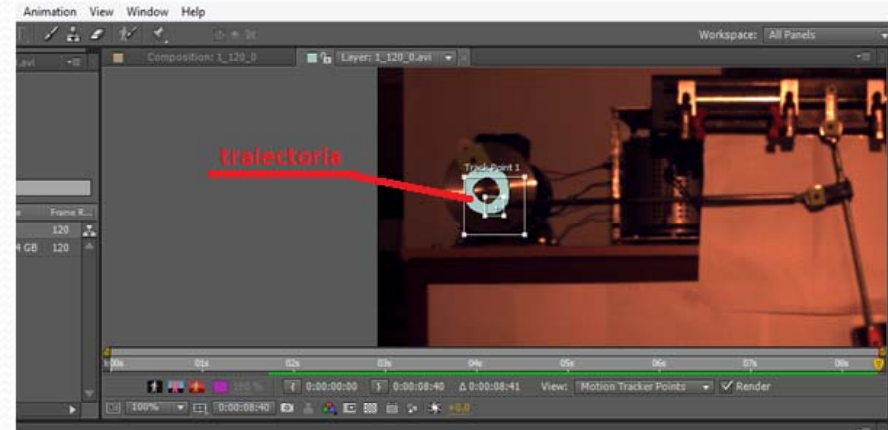

The path of marker 1

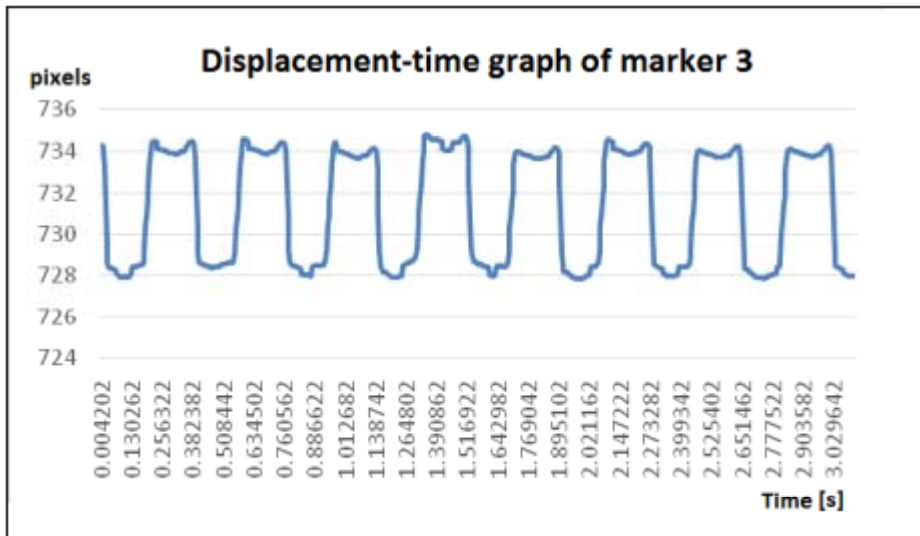

Horizontal speed of the slide

Horizontal speed of the slide

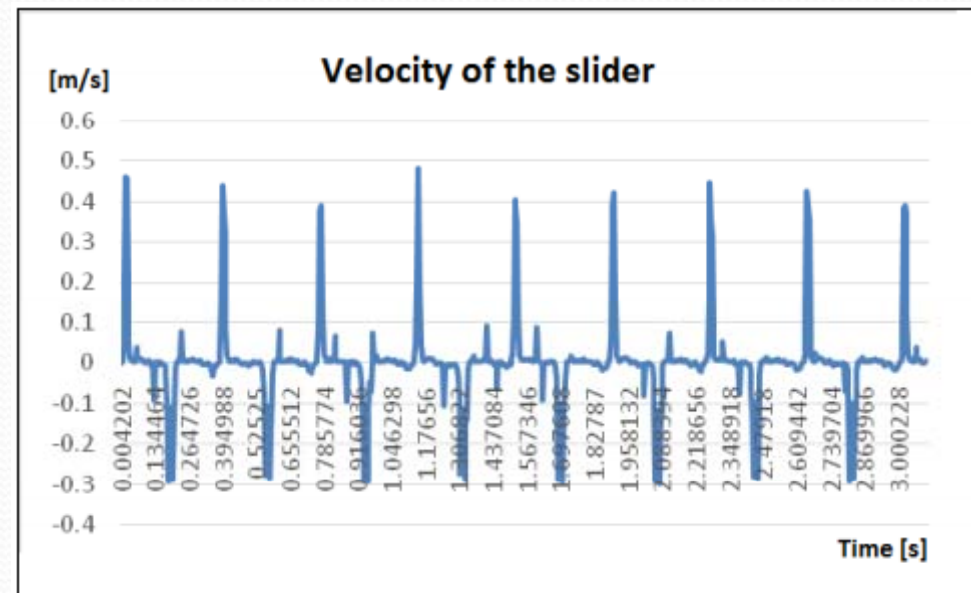

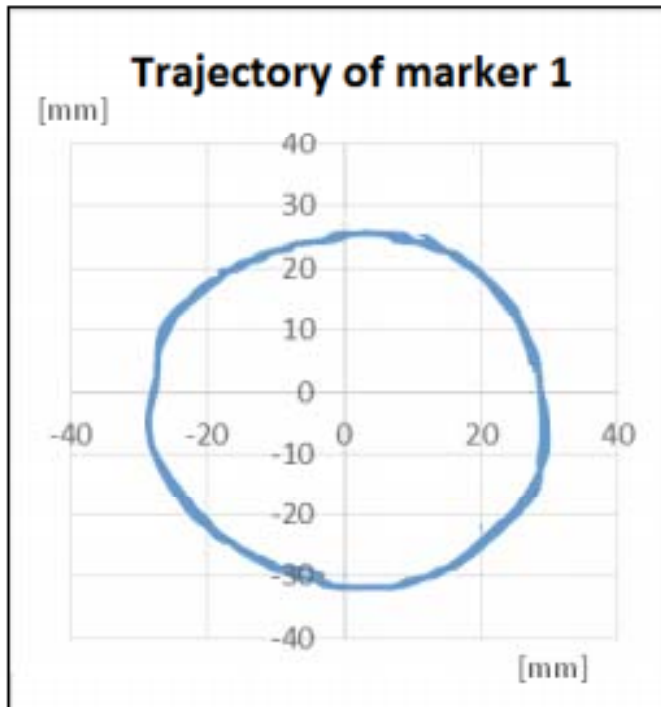

Trajectory of marker 1

Horizontal displacement
of marker 1

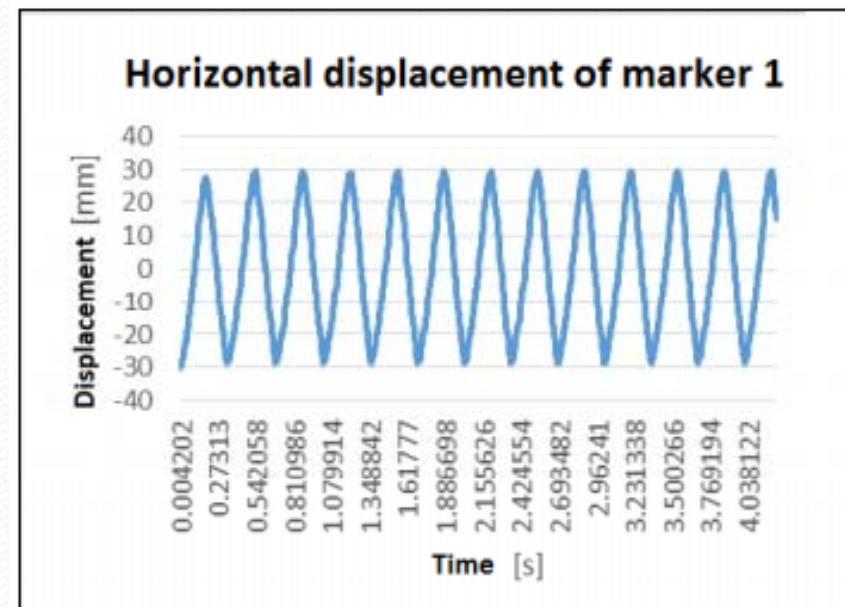
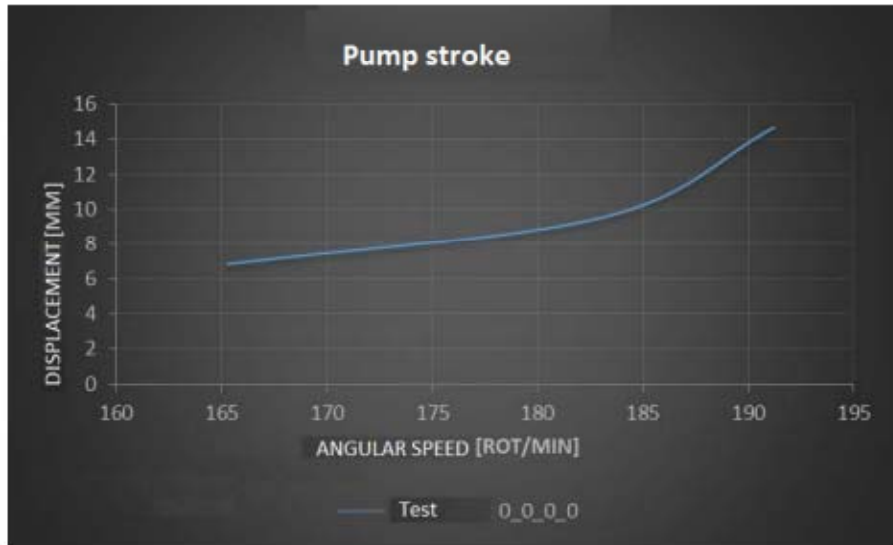
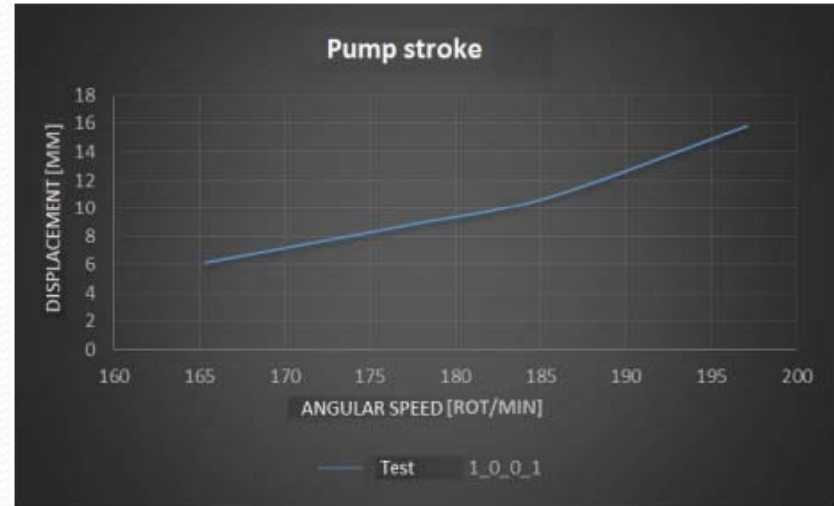

Table 1.2.

Regime	TAP POSITION					
	0_0_0_0		1_0_0_1		1_1_1_1	
	Angular speed (rot/min)	Displacement (mm)	Angular speed (rot/min)	Displacement (mm)	Angular speed (rot/min)	Displacement (mm)
100	165.36	6.84	165.24	6.16	161.73	6.05
120	183.15	9.58	176.93	8.74	163.71	8.04
140	191.21	14.67	185.26	12.76	184.18	11.62
160	197.11	15.86	192.56	15.30	191.67	15.04



The displacement of the piston 0_0_0_0



The displacement of the piston 1_0_0_1

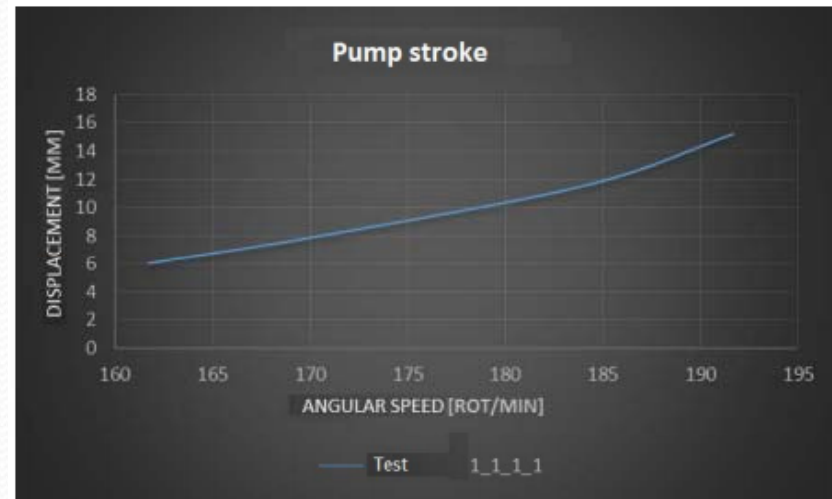

The displacement of the piston 1_1_1_1

CONCLUSIONS

This mechanism property provides the following benefits:

- Allow startup of the vertical axis wind turbine at low wind speeds (thus avoiding the disadvantage of this type of wind turbines);
- Accomplishes an increase of pump turbine efficiency with the increase of wind speed. This is obvious if you notice that as speed increases, both the number of racing pistons in unit time and the length of its stroke increase;
- Limits the speed in case of strong wind turbine, by substantially increasing the power consumed by the pump;



Chapter 2

ANALYSIS OF THE MOTION EQUATIONS AND DYNAMIC RESPONSE OF THE MULTIBODY SYSTEM WITH ELASTIC ELEMENTS

2.1. Modeling the multibody systems with elastic elements

2.2. Eigenvalues and eigenmodes of a cardan joint

2.3. Finite Element Analysis of a Two-Dimensional Linear Elastic Systems with a Plane “Rigid Motion”

2.4. Some properties of motion equations

Modeling the multibody systems with elastic elements

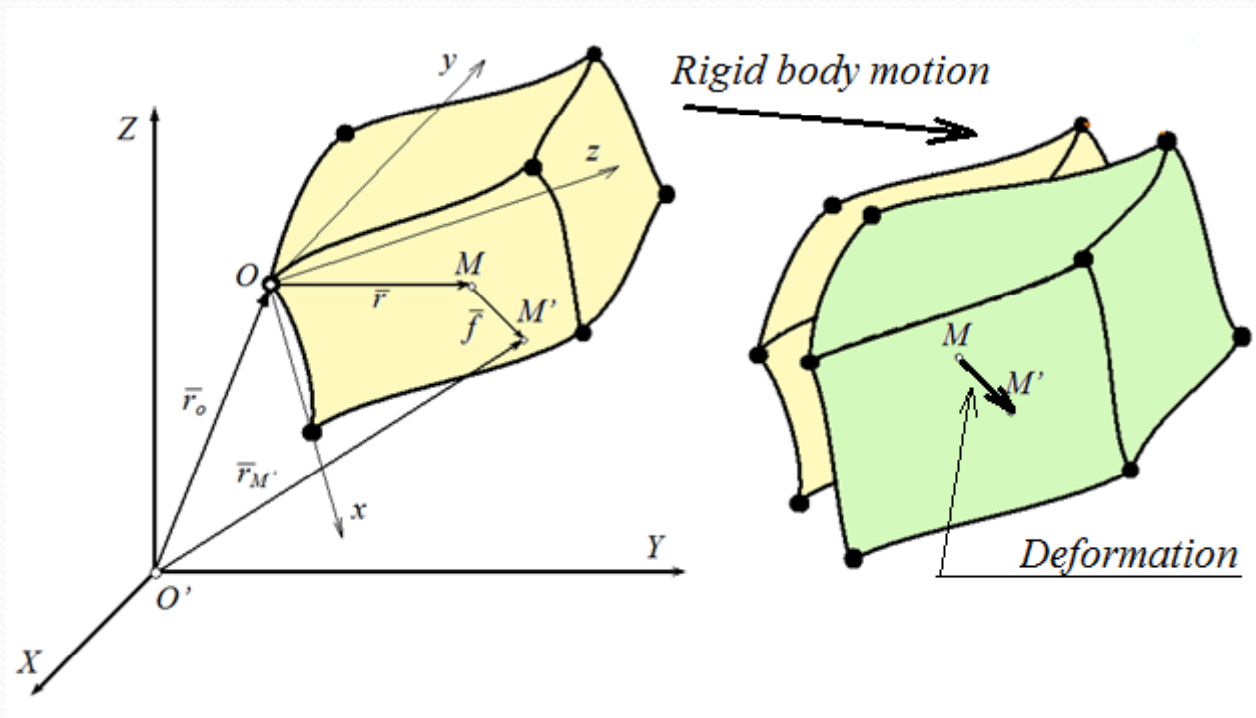

Representative finite element

Eigenvalues and eigenmodes of a cardan shaft

The cardan joint analysed

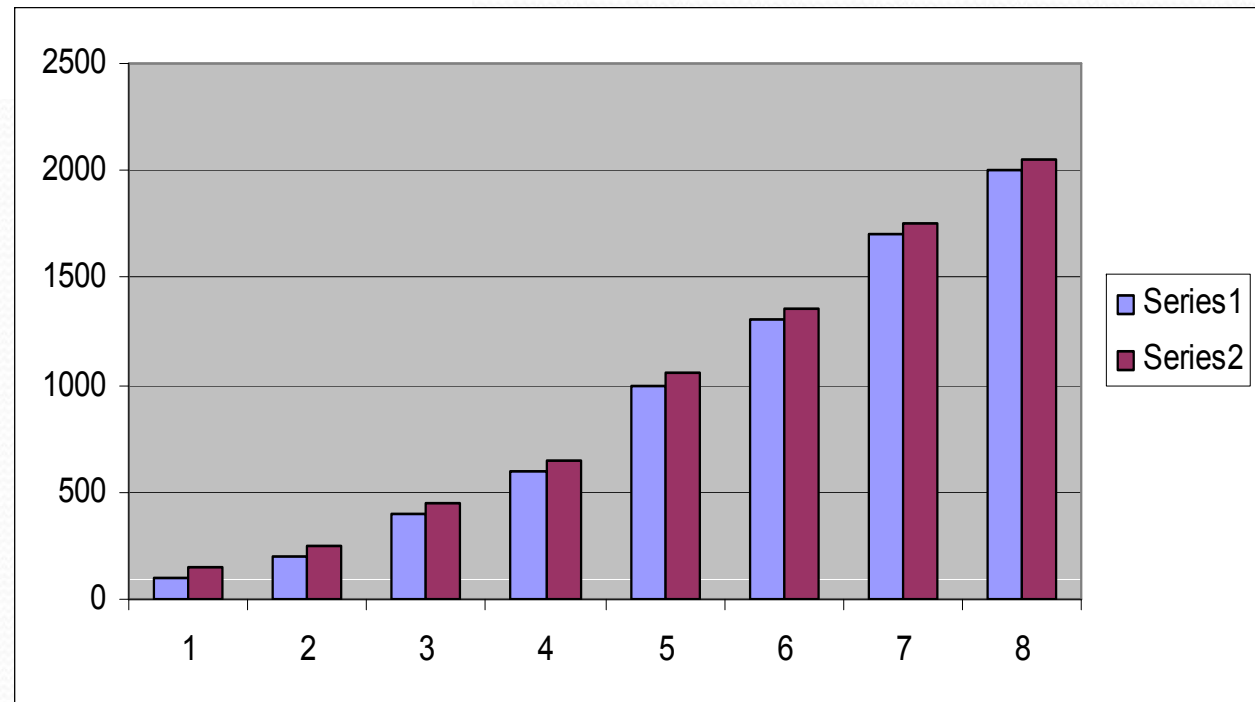

The first six eigenmodes corresponding to the non null eigenvalues

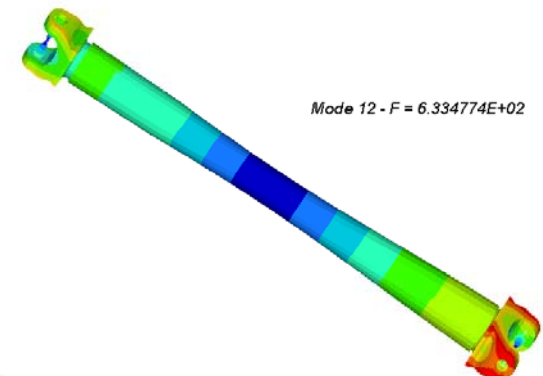
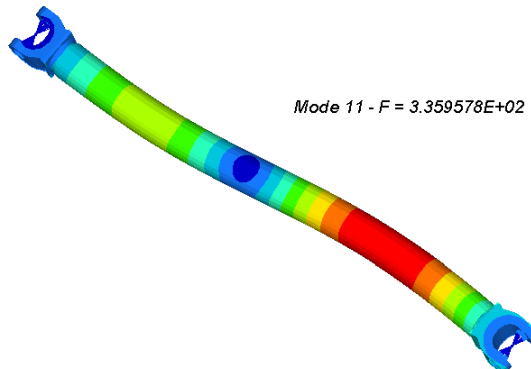
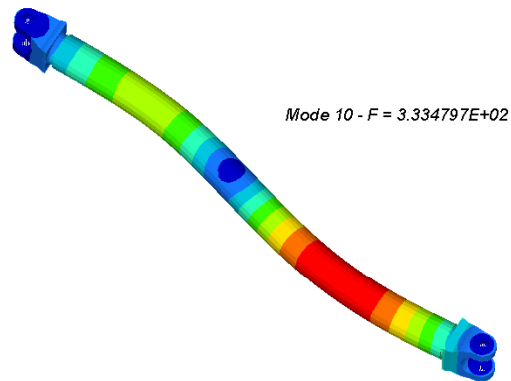
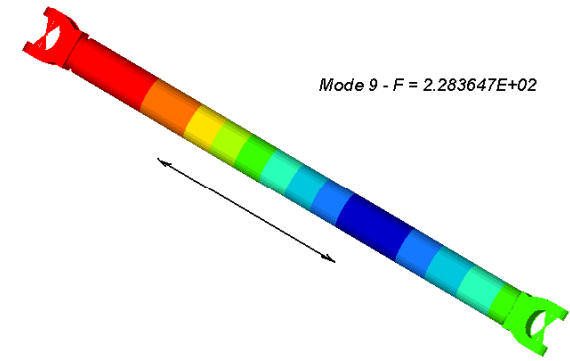
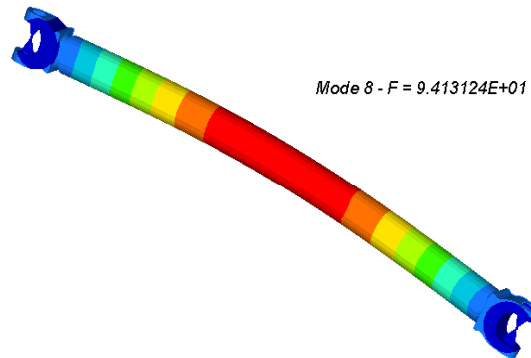
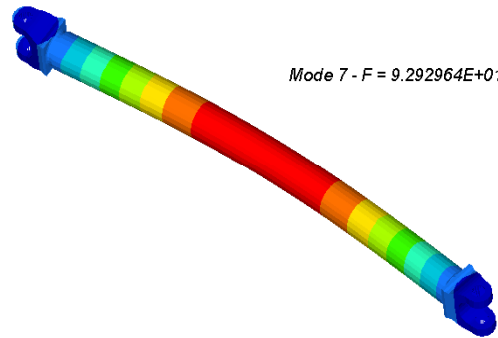

Finite Element Analysis of a Two-Dimensional Linear Elastic Systems with a Plane “Rigid Motion”

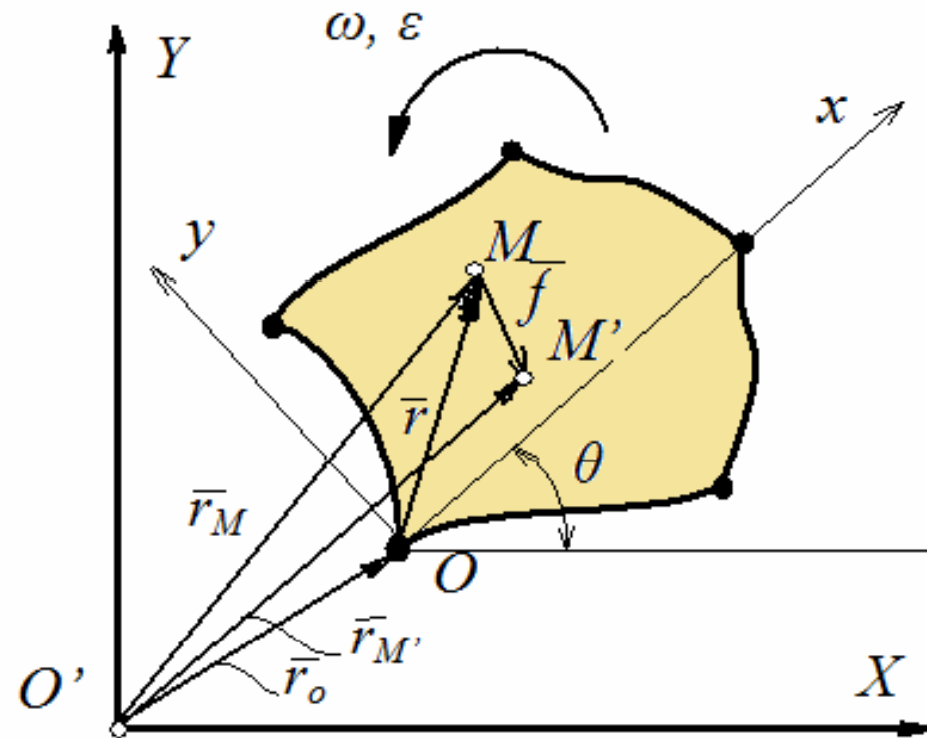

A two-dimensional finite element with plan motion

The eigenmodes for a disk - deformation situated in a plane

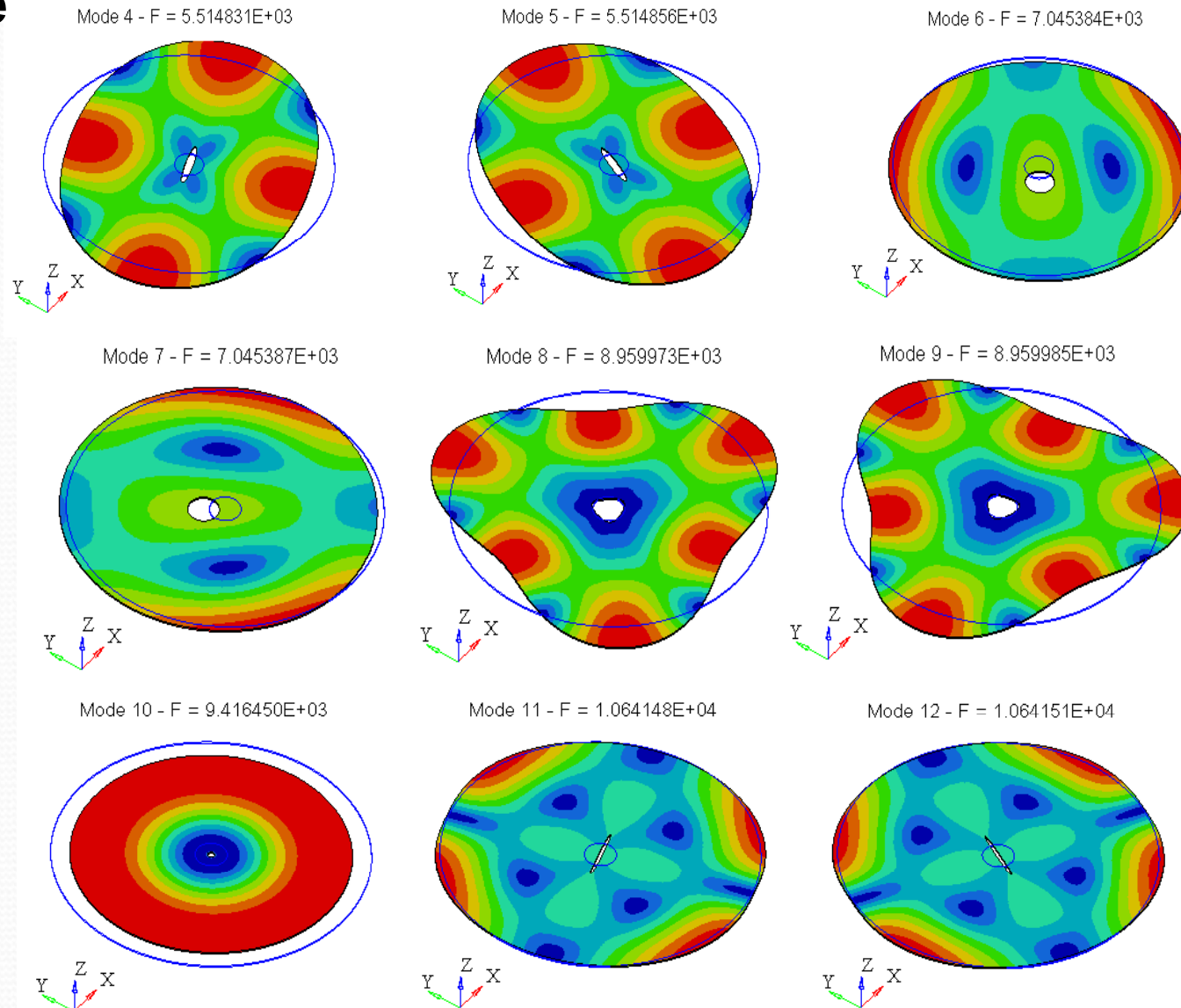

Mode 13 - $F = 1.171302E+04$

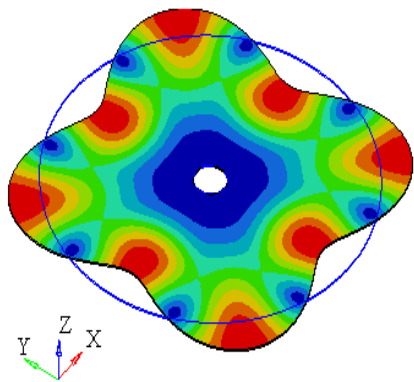

Mode 14 - $F = 1.171303E+04$

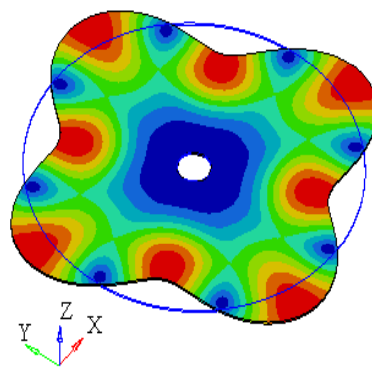

Mode 15 - $F = 1.276671E+04$

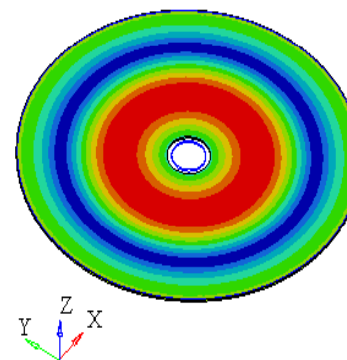

Mode 16 - $F = 1.428423E+04$

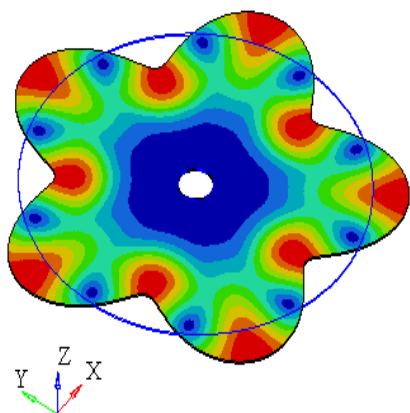

Mode 17 - $F = 1.428425E+04$

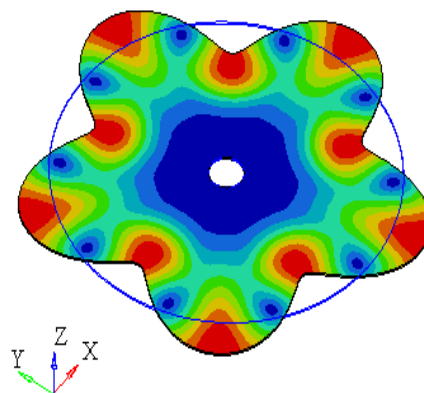

Mode 18 - $F = 1.491042E+04$

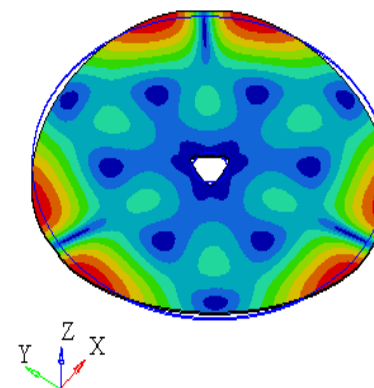

The eigenmodes for a disk - deformation situated perpendicular to a plane

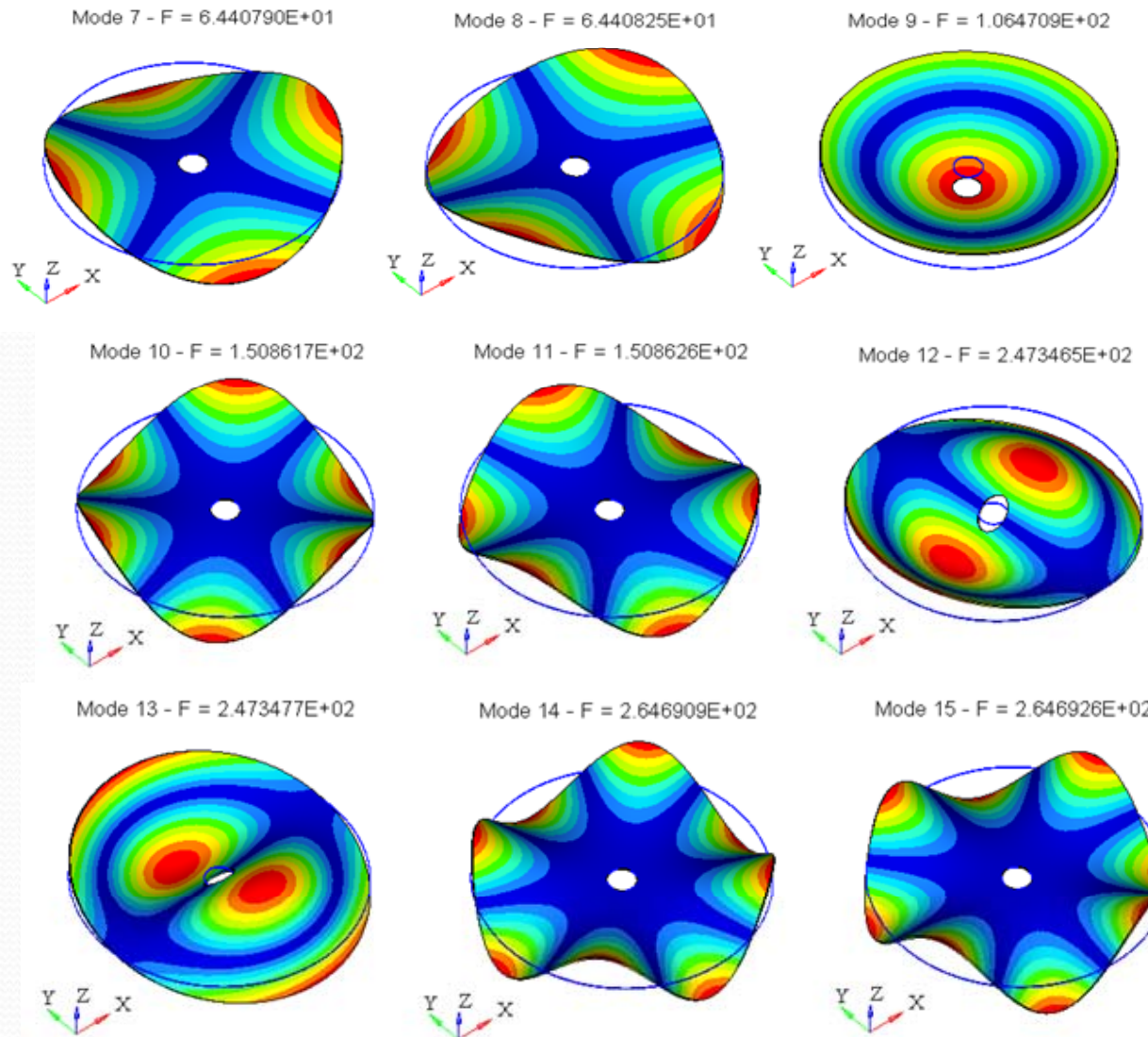

CONCLUSIONS

In this section are presented some mathematical properties of motion equations in the case of multibody systems having elastic elements.

These properties are due to the existence of the skew symmetrical matrix C , by which the relative motion of nodal coordinates is manifested by the Coriolis effects and the additional term introduced in equations (applying the finite element method);

Using these properties is possible to allow a qualitative analysis of the obtained motion equations.

Chapter 3

MECHANICAL PROPERTIES IDENTIFICATION AND TESTS ON ADVANCED COMPOSITE MATERIALS

Mechanical Properties of a Sandwich Composite with twill weave carbon and EPS

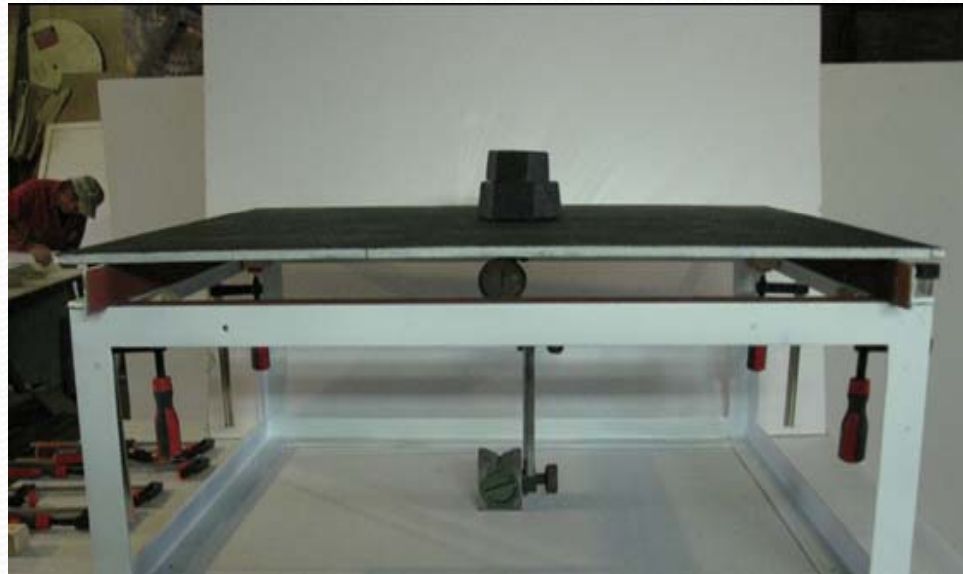

Flexural load-unload test detail. Sandwich panel clamped on contour



Tensile test detail on an epoxy impregnate 2/2 twill weave carbon fabric

Characteristics	Value
Length between extensometer's lamellae (mm)	50
Preload stress (kN)	0.0056
Preload speed (mm/min)	21
Test speed (mm/min)	1
Fabric width (mm)	18.5
Fabric thickness (mm)	0.4
Stiffness determined as ratio between load and extension (N/m)	578 5656.99
Young's modulus (MPa)	31273.82
Load at maximum load (kN)	1.92
Stress at maximum load (MPa)	207.61
Strain at maximum load (-)	0.009
Strain at maximum extension (-)	0.344
Strain at minimum load (-)	0.07
Load at minimum extension (kN)	0.005
Stress at minimum extension (MPa)	0.582
Load at break (kN)	1.919
Stress at break (MPa)	207.55
Strain at break (-)	0.009
Tensile strength (MPa)	207.61

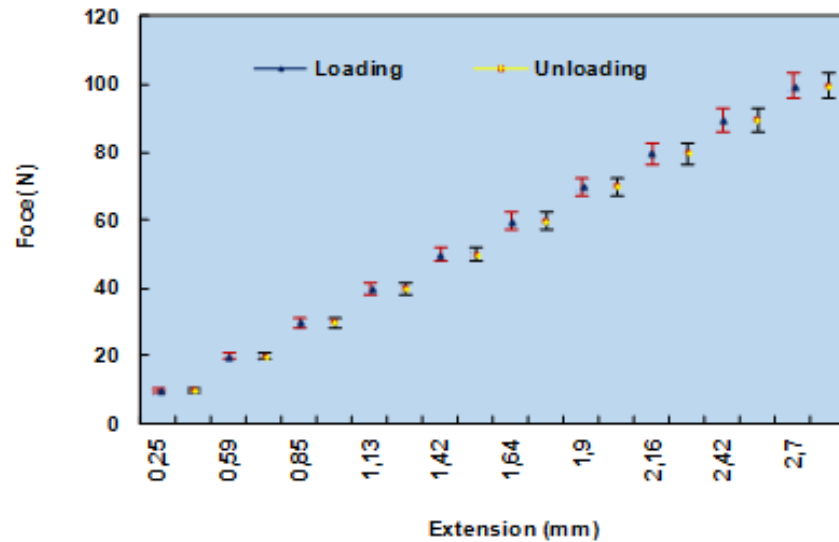

Three-point bend test
of the sandwich panel supported
linearly on two opposite edges.

Force-extension distribution on
10 mm thickness specimen subjected
to three-point bend test.

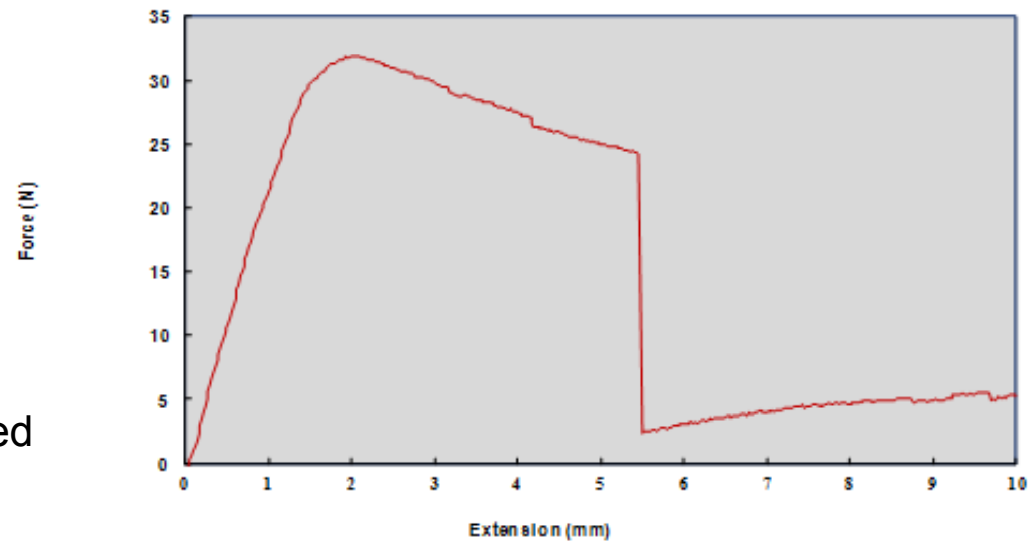

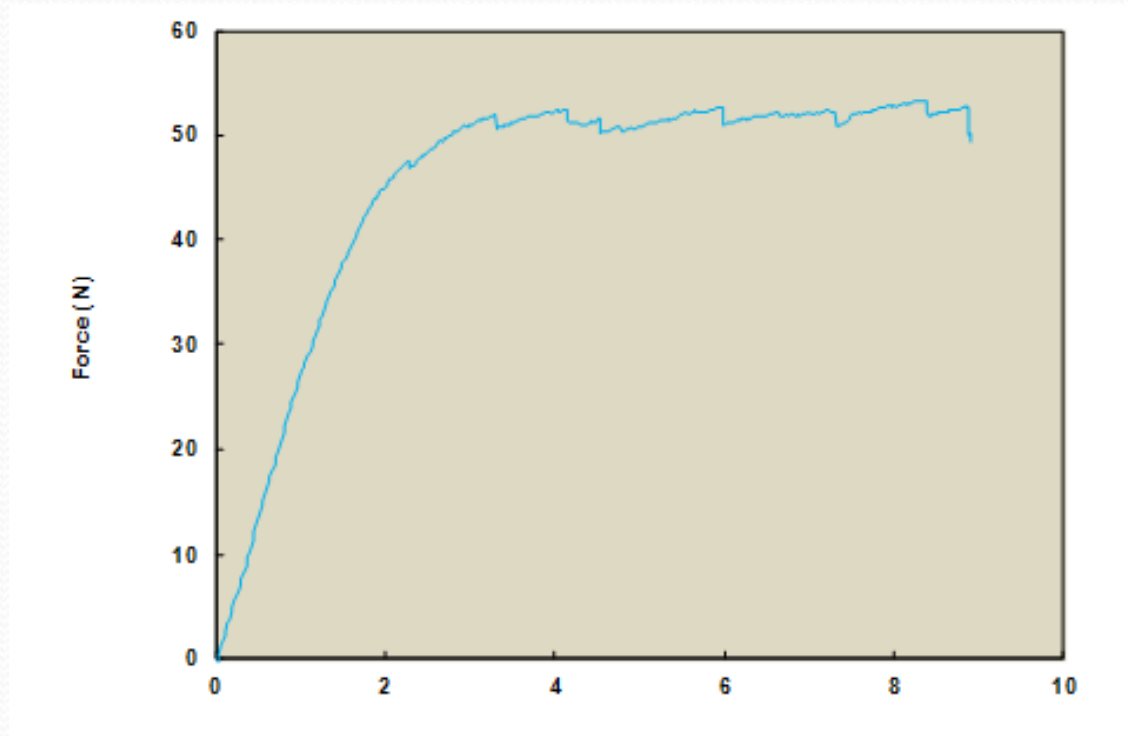

Force-extension distribution on 30 mm thickness specimen subjected to three-point bend test.

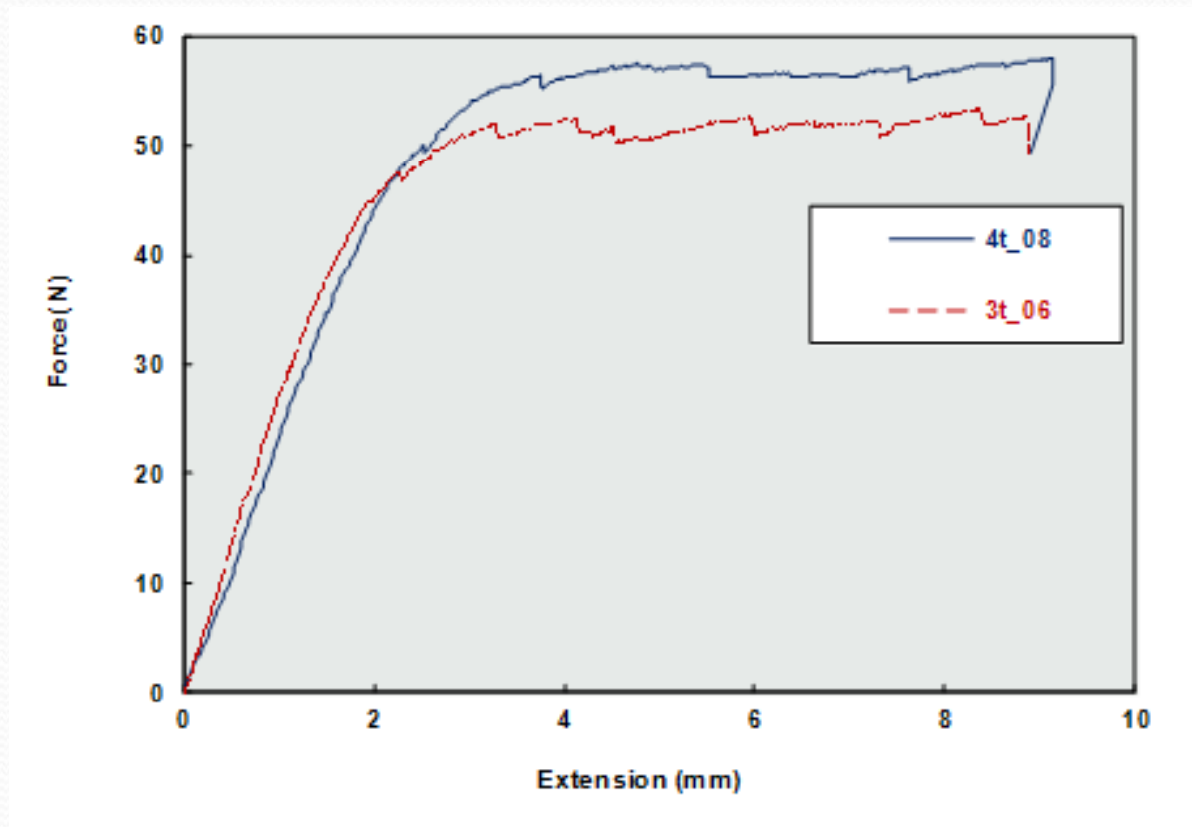

Comparison between force-extension distributions on 30 mm and 40 mm thickness specimens subjected to three-point bend tests.



The following conclusions can be drawn:

- The sandwich structure's strains with skins based on twill weave carbon fabric reinforced epoxy resin are comparable with those of the structure with skins based on EWR-300 glass fabric/epoxy resin;
- Stresses in fibres direction in case of the sandwich structure with carbon fabric/epoxy resin reinforced skins, are up to six times higher than those existent in EWR-300 glass fabric/epoxy resin skins;
- Stresses transverse to the fibres direction in case of the sandwich structure with carbon fabric/epoxy resin reinforced skins are 20% lower than those existent in EWR-300 glass fabric/epoxy resin skins;

On the polylite composite laminate material behavior to tensile stress on weft direction



RT300 glass fabric reinforcing material



RT300 glass fabric-reinforced
Polylite 440-M888 polyester resin specimens
cut on weft direction

Specimens' maximum mechanical properties with 1 mm/min test speed

Feature	Value
Load at maximum load (kN)	11.57
Load at break (kN)	11.567
Young's modulus (MPa)	7446.2
Tensile strength (MPa)	312.74
Stress at break (MPa)	312.61
Strain at break (-)	0.077
Stress at minimum extension (MPa)	0.109
Strain at maximum load (-)	0.077

Specimens' maximum mechanical properties with 2 mm/min test speed

Feature	Value
Load at maximum load (kN)	10.778
Load at break (kN)	10.386
Tensile strength (MPa)	320.76
Stress at break (MPa)	309.11
Strain at break (-)	0.078
Stress at minimum extension (MPa)	0.104
Strain at maximum load (-)	0.077
Strain at maximum extension (-)	0.078

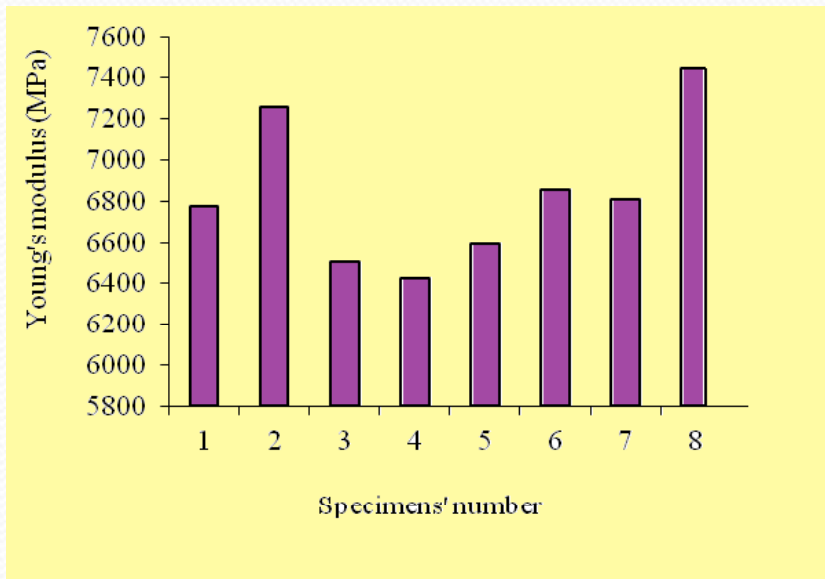

Young's modulus distribution of eight RT300 glass fabric-reinforced PolyLite 440-M888 polyester resin specimens (1 mm/min test speed)

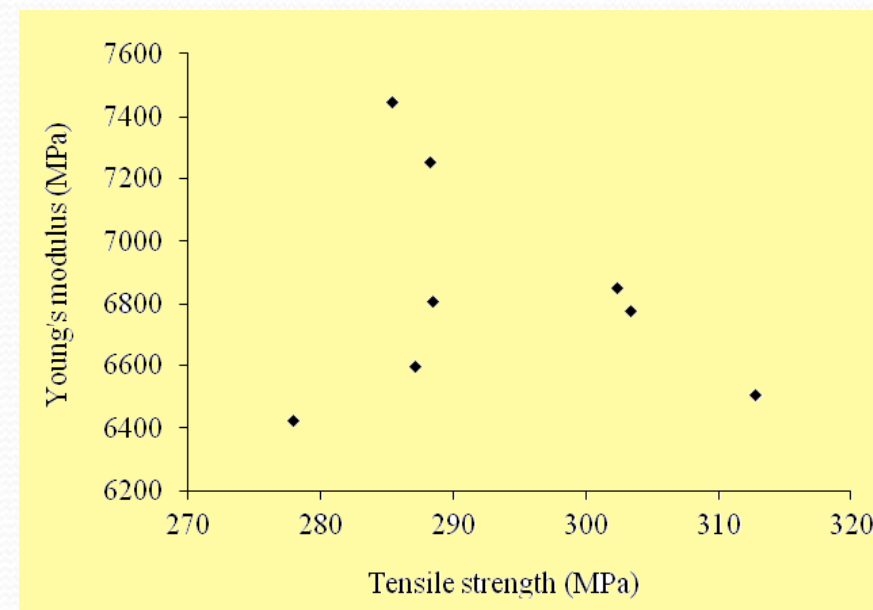

Young's modulus distribution versus tensile strength of eight RT300 glass fabric- reinforced PolyLite 440-M888 polyester resin specimen (1 mm/min test speed)



The following conclusions can be drawn:

- The Young's modulus distribution of twelve layers RT300 glass fabric-reinforced PolyLite 440-M888 polyester resin specimens cut on weft direction presents a maximum value of 7446.16 MPa at specimen 8 and a minimum value of 6424.94 MPa at specimen 4 ;
- The first failures take place at a strain value of 0.025 – 0.035 for both test speeds. These failures appear due to delamination. The delamination is not so spectacular than in case of chopped strand mats reinforced polyester resin laminates. ;
- Due to good drape ability of RT300 glass fabrics, these reinforcing materials are widely used in most common polyester based composite structures.;

Hybrid carbon-hemp composite laminate used in automotive engineering impact applications

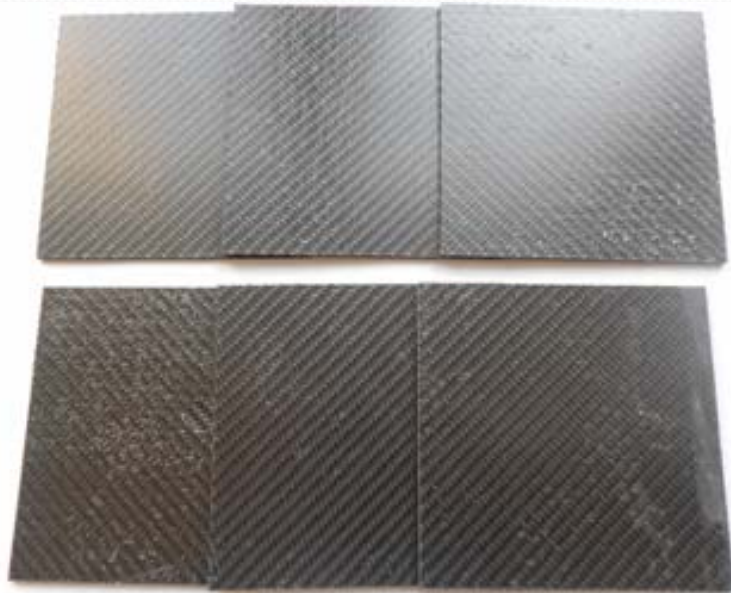

Carbon-hemp composite laminate



The impact device

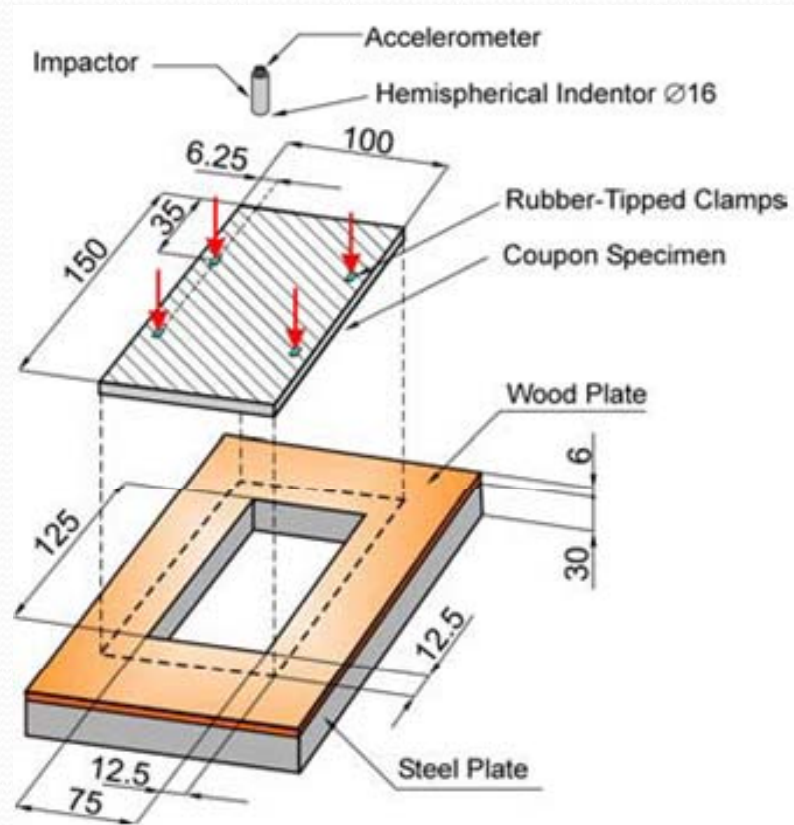

$$H = \frac{v^2}{g} [m]$$

$$a(t) = g - \frac{F(t)}{m} (m/s^2)$$

$$U(t) = \int_0^t F(t) \cdot v(t) \cdot t$$

The specimen's geometry and fixing mode

Results

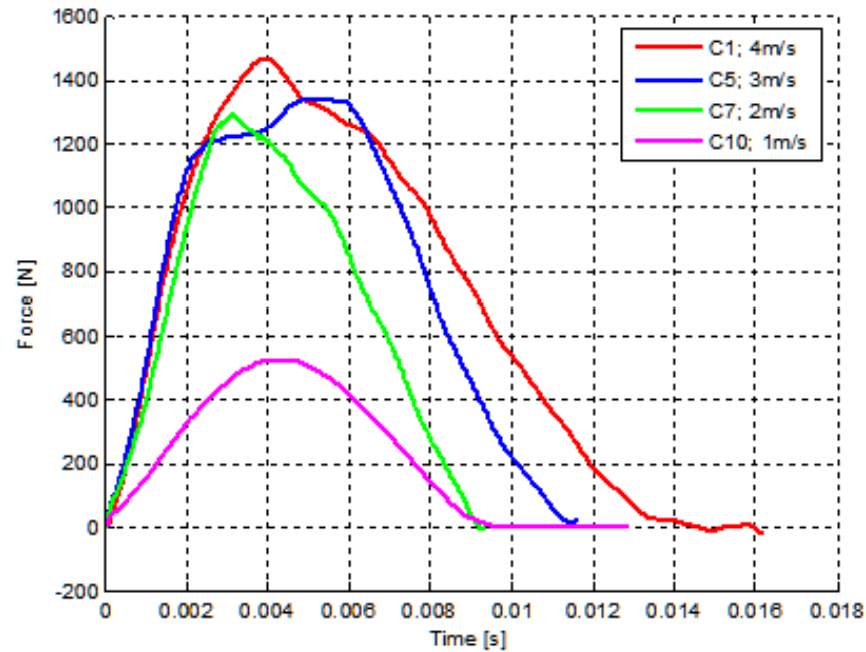

Force-time (F-t) distribution at the impact's moment

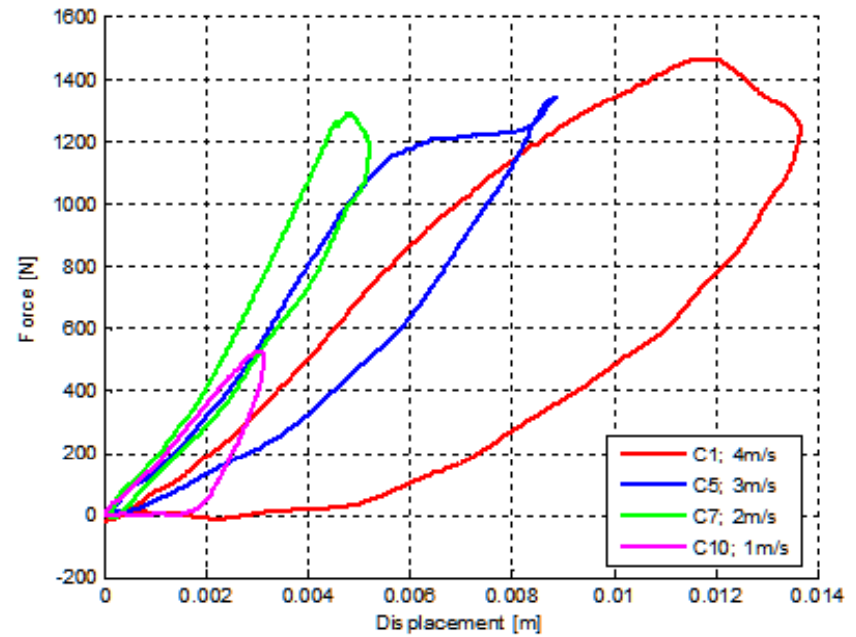

Force-displacement (F- δ) curves at the impact's moment

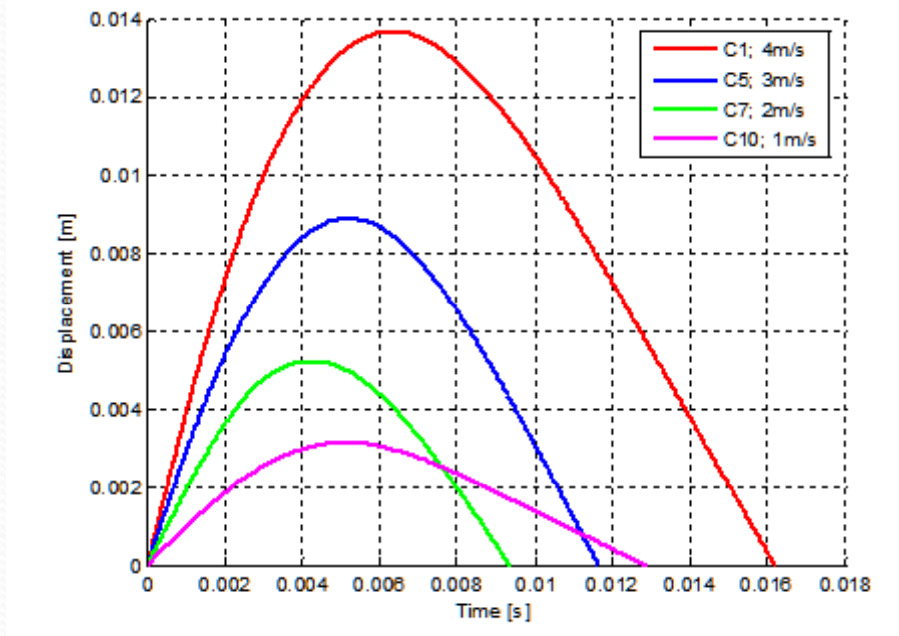

The variation of indenter's displacement δ at the impact's moment

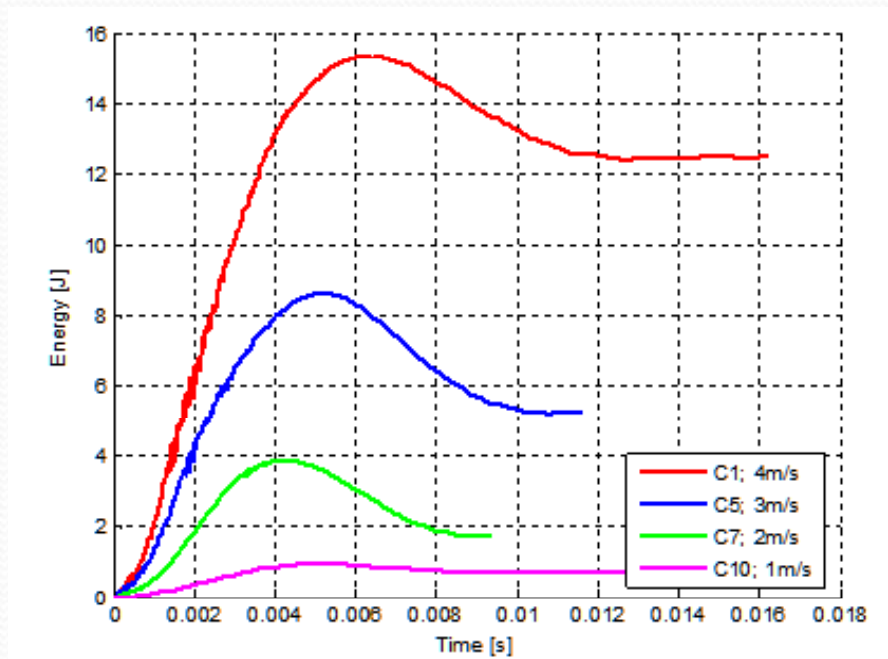

The variation of energy U at the impact's moment



The following conclusions can be drawn:

- Integrating the area under the loading curve (force-displacement) until the maximum value of the force (according to the first failure) the energy required to initiate the failure can be obtained;
- At the impact's moment, the energy accumulates in time and is direct proportional with the force and increases until reach a constant landing;
- In general, at the composite laminates the energy is frequently absorbed by creating some delamination surfaces called delamination breaks that lead to the strength and stiffness decrease

Chapter 4

TOWARD THE USE OF IRRADIATION FOR THE COMPOSITE MATERIALS PROPERTIES IMPROVEMENT

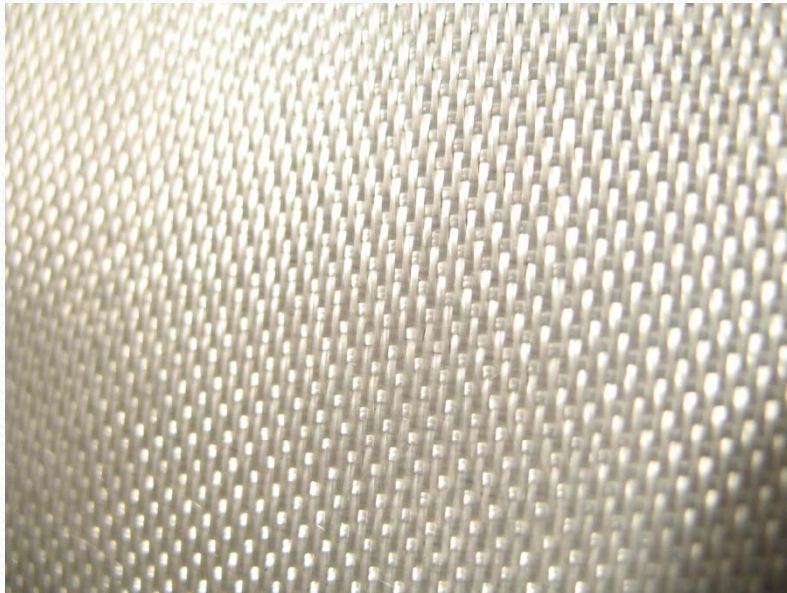

Glass fiber composites materials

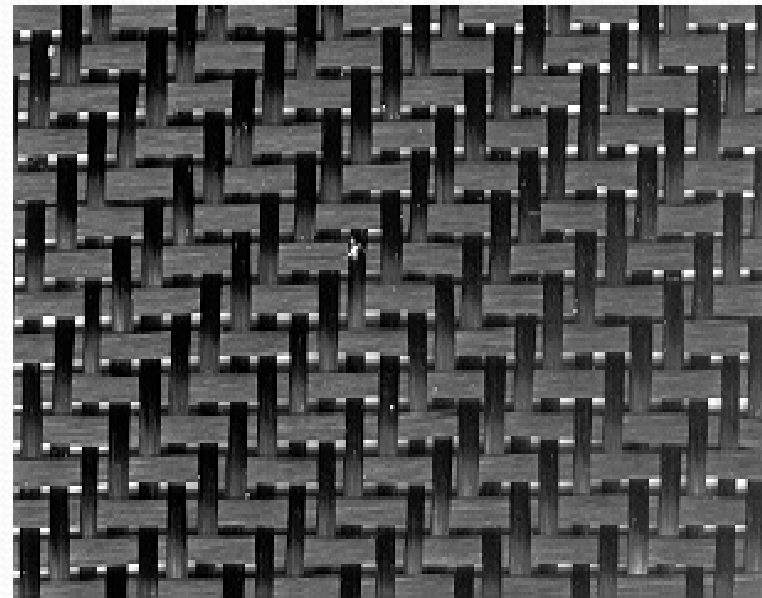

Carbon fiber composites materials



a.



b.



c.



d.



e.



f.

Vegetable fiber
reinforced



Hemp fiber
reinforced

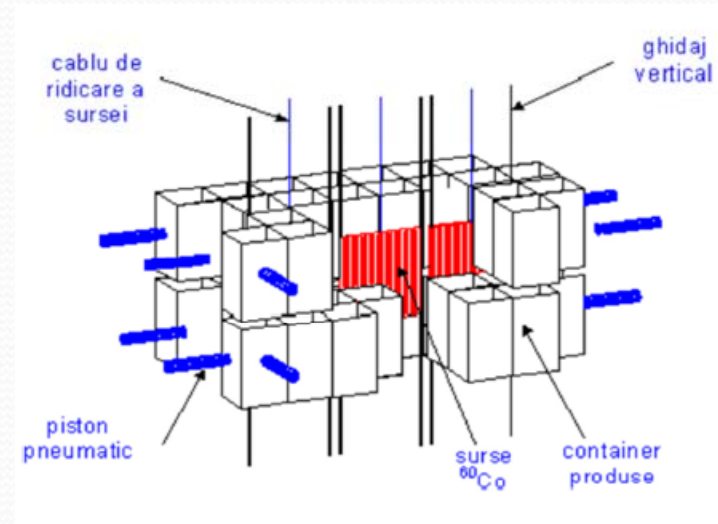
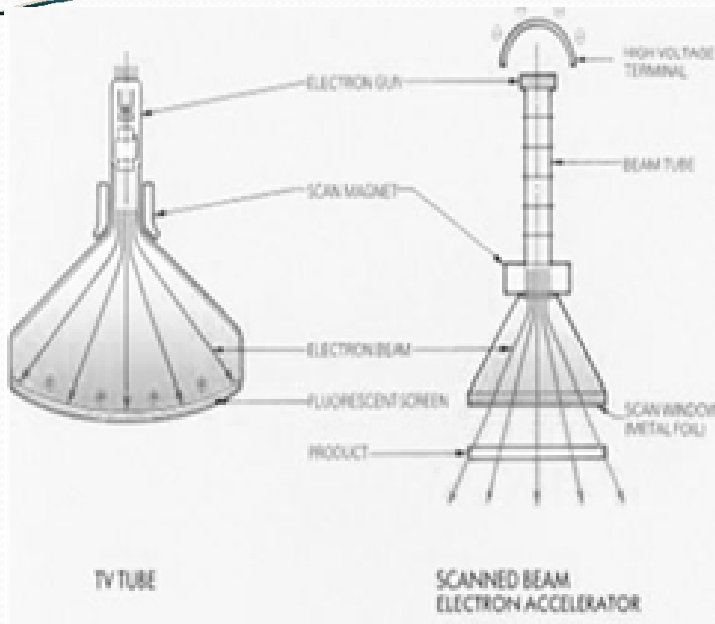

Internal conveyor and their sources of Co-60

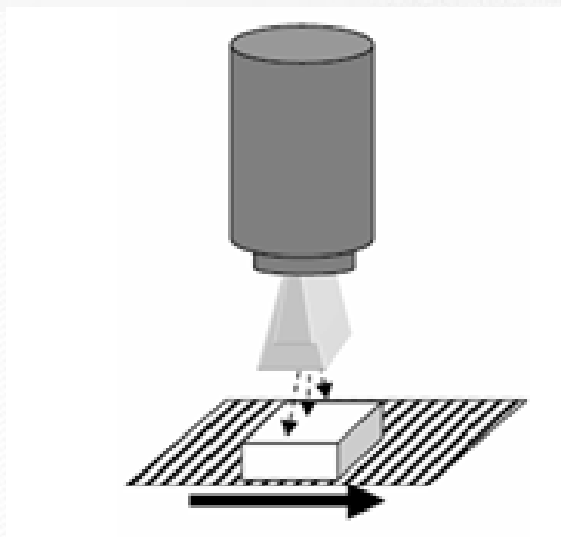

Schematic representation of an irradiator with electrons accelerator



Hemp specimen during the tensile test

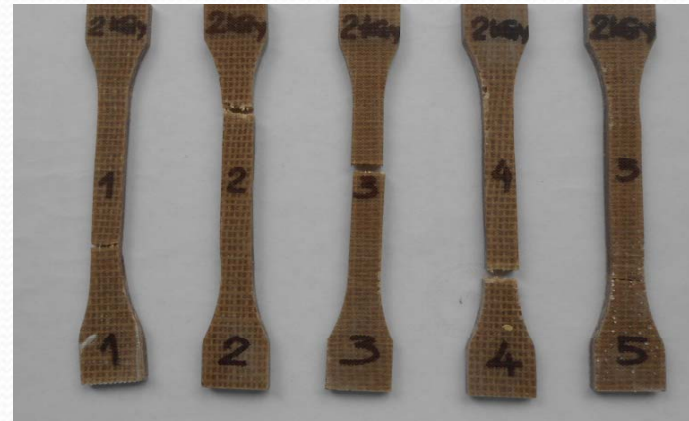

Hemp fabric based specimens irradiated with 2 kGy dosis



Hemp fabric based specimens irradiated with 56,7 kGy dosis



The VHX digital microscope

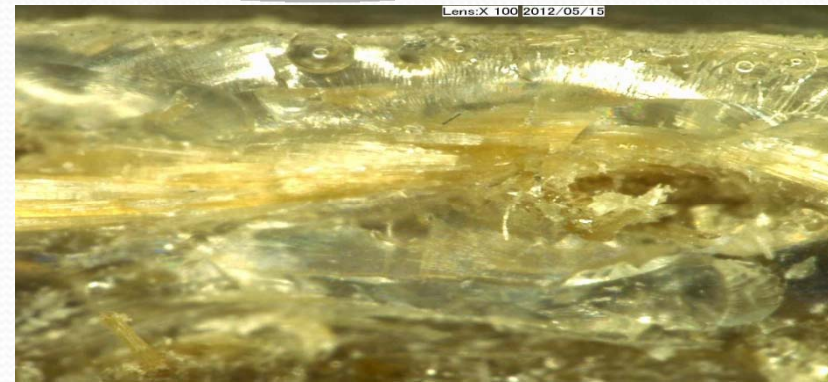

Cross-section through a hemp fabric based specimen irradiated with 2 kGy dosis (100X magnitude)



Cross-section through a hemp fabric based specimen irradiated with 56.7 kGy dosis (100X magnitude)

Some results

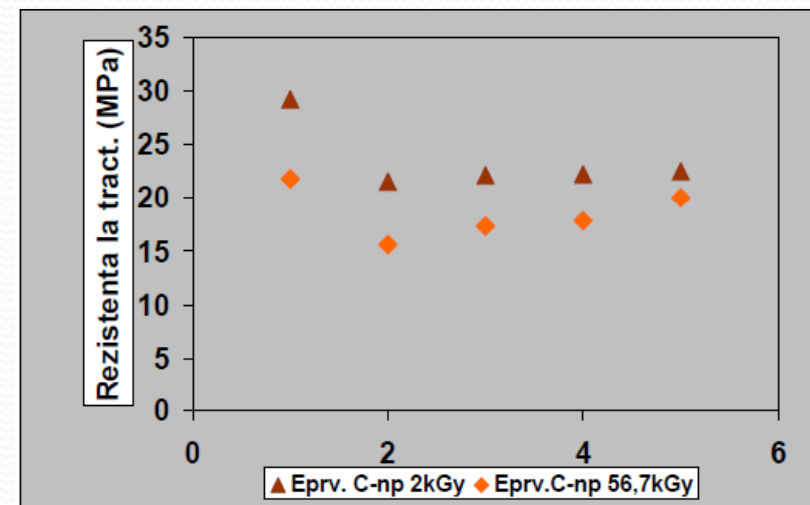
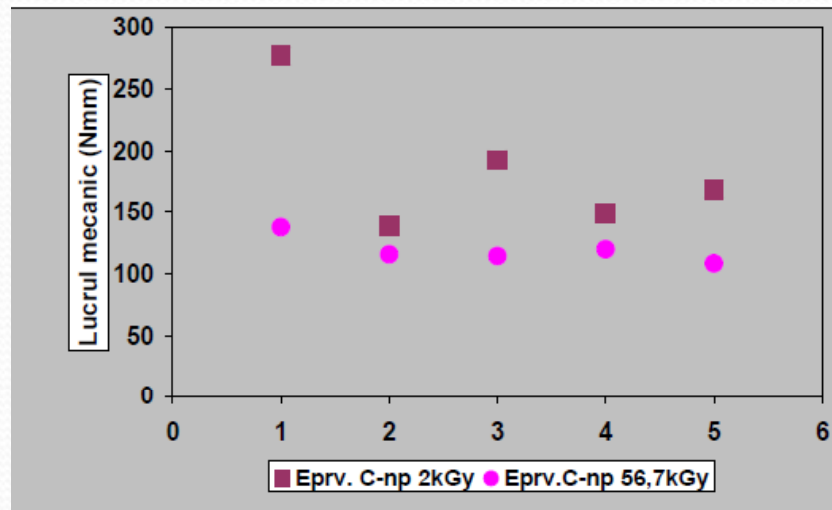
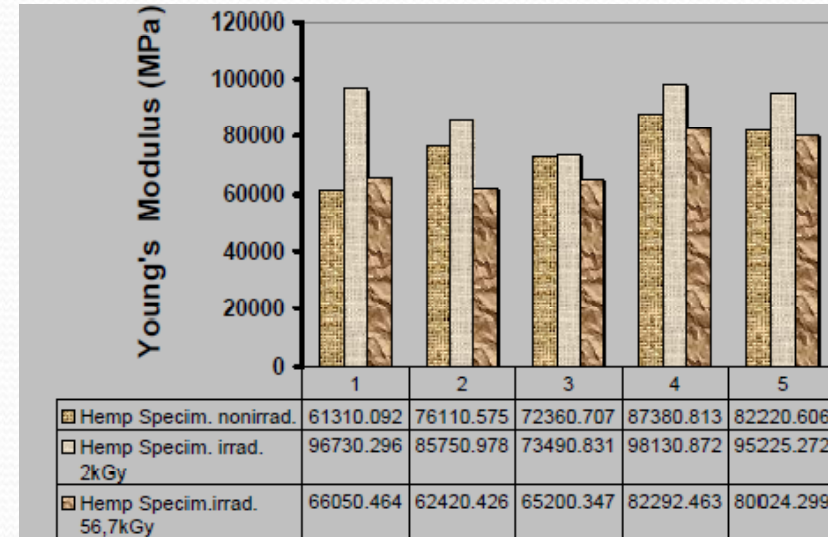
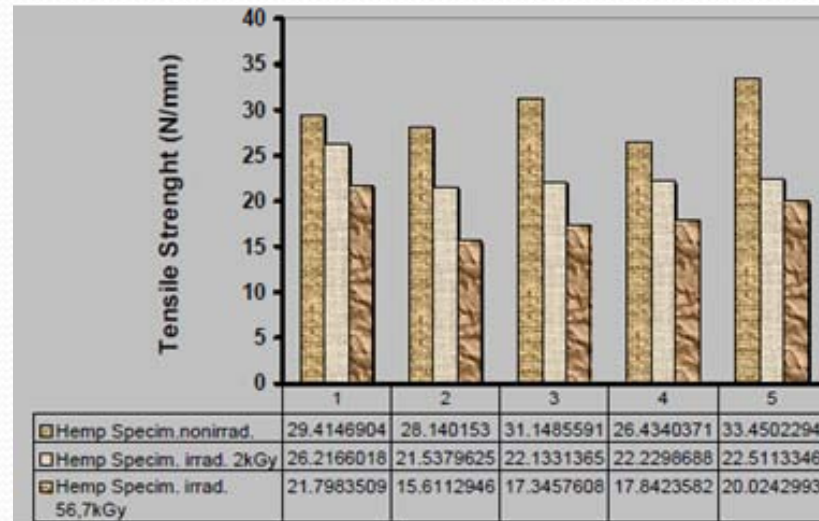

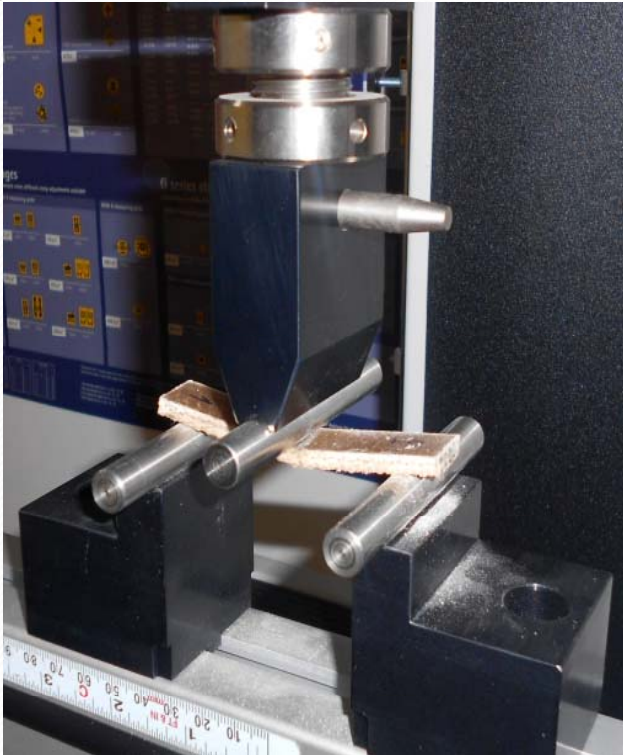

Glass-Hemp specimen during the test



Hybrid glass-hemp specimens, before test



Hybrid glass-hemp specimens, after test

Some results

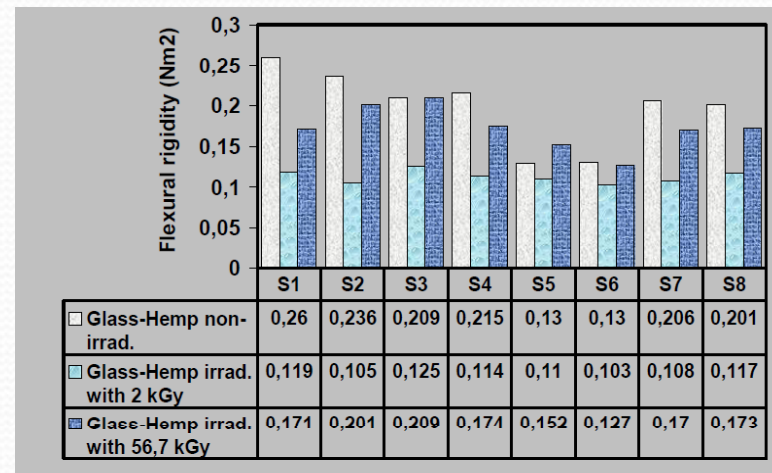
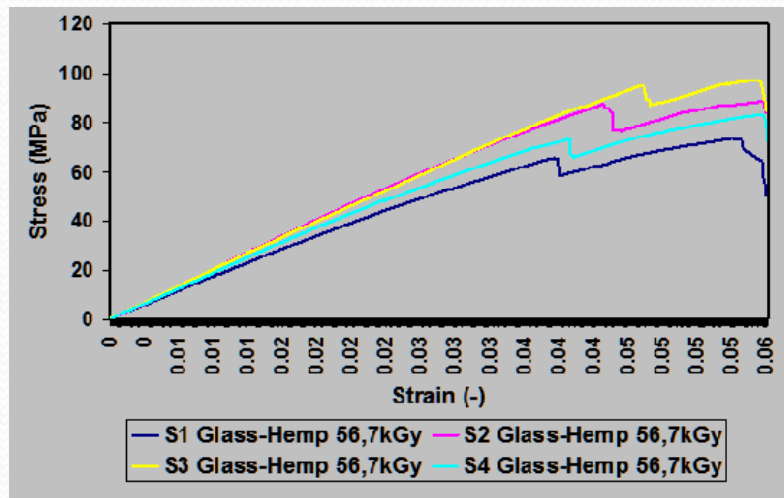
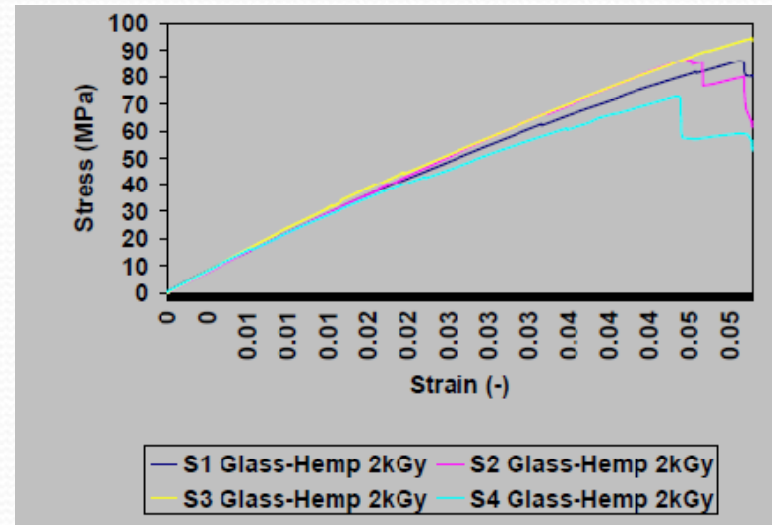
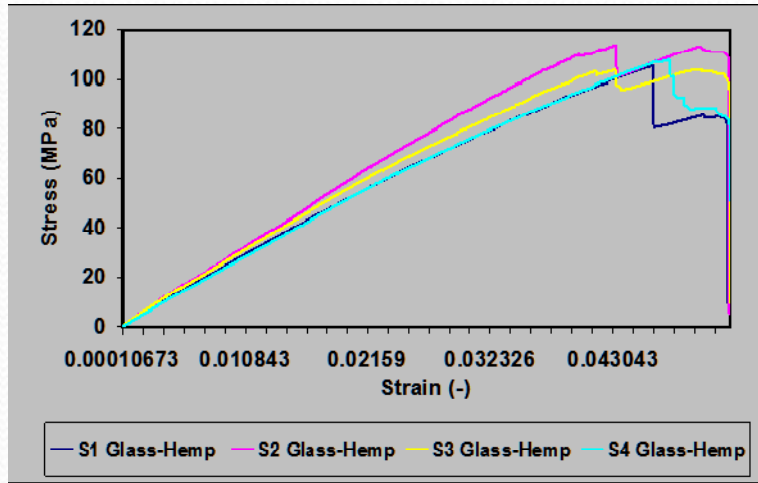



Carbon-hemp specimen during three-point bending test



Some results

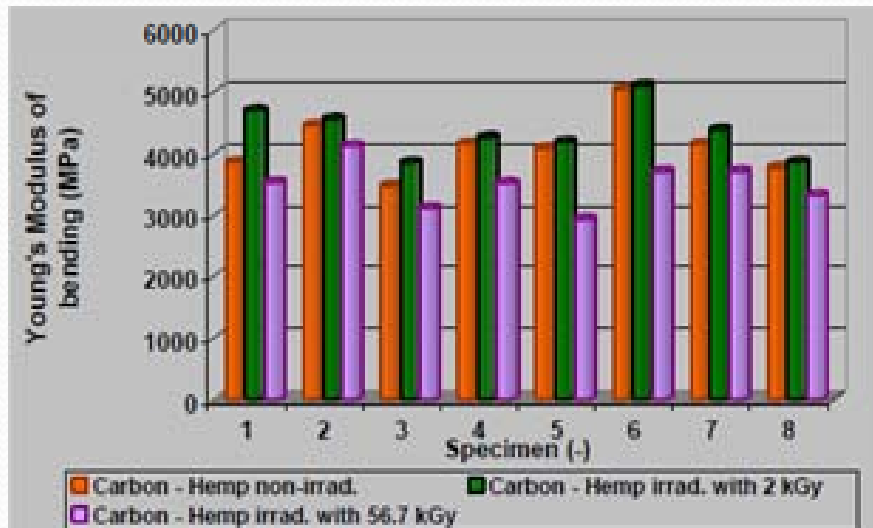

Young's modulus of bending distributions of non-irradiated and irradiated carbon-hemp composite specimens

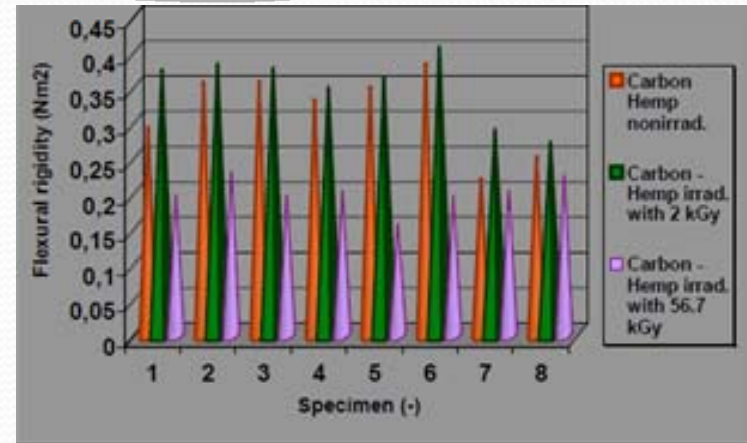

Flexural rigidity distributions of non-irradiated and irradiated carbon-hemp composite specimens

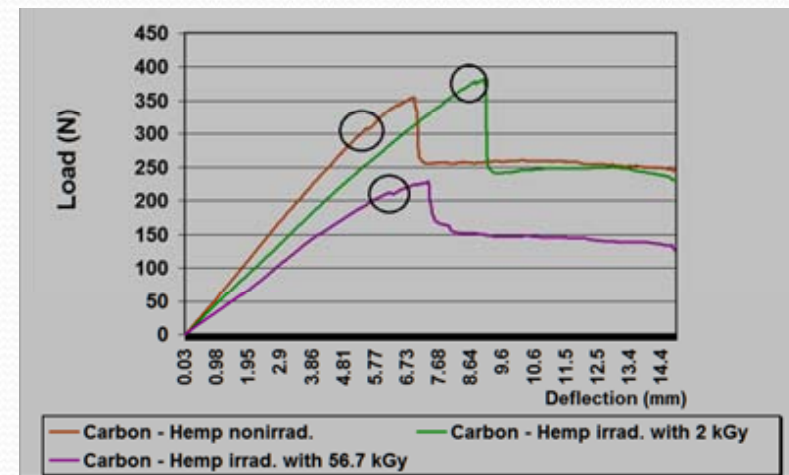

Load-deflection distributions of specimen no. 4 with registration of first failure

FINAL CONCLUSIONS

- Two different direction of research: composite materials and dynamic response of the multibody systems;
- Results: papers published in ISI indexed journal (16), monographs in the field (3);
- Grant and research project in these two research fields – 16 research project;
- Very good collaboration in a team.



The evolution and development plans for career development

Teaching activity

- Updating and upgrading of teaching syllabuses to ensure consistency of content and task specialization;
- Implementation and development of modern technologies for teaching and learning in order to ensure adequate professional training practical realities; promoting methods of analysis, research methodologies, models of organizing activities with the participation of creative teaching; application of teaching methods based on information technology;
- Upgrading and equipping of laboratories for practical activities extend to subjects taught;

Research activity

- Participation at national and international conferences to sustain the research results of PhD students in the field of mechanics;
- Publication of scientific papers in journals with impact factor in vederea national and international recognized;
- Development of partnership agreements to facilitate PhD students to participate at these research infrastructures.

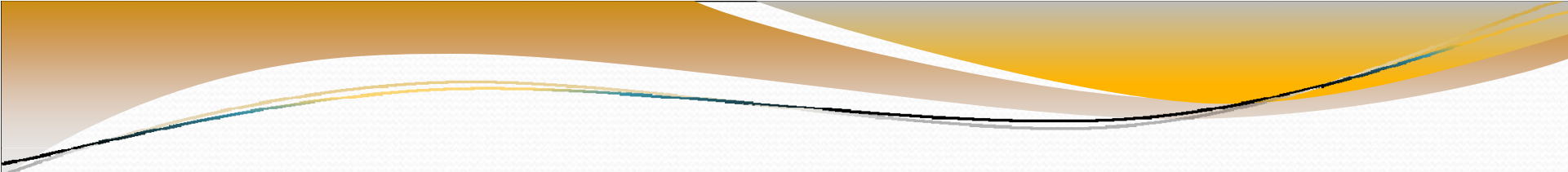

Thank you
😊
for your attention !!!!